

Application:

- Stopping and/or holding brake for rotors of wind turbines

Description:

- The SHI 75 FC brake is a [Fail Safe Brake, Spring Applied, Hydraulically Released](#); braking force adjustable by variation of air gap and by variation of spring package.
- The SHI 75 FC brake is designed as a floating caliper.
- SHI brakes are suitable for horizontal and vertical brake discs under any angular displacement.

Design Advantage:

- Compact and robust construction
- Fast response time; fast braking for maximum safety
- Stainless steel piston
- Sinter linings for high speed/high energy application
- Retraction springs ensure air gap between lining and disc when brake is open
- Optimized lining pressure distribution by innovative force transmission
- Optimized isolation of lateral forces
- Minimized risk of leakage
- Suitable for low temperature applications
- Long service life
- Easy maintenance

		SHI 75-FC
Piston area	A_P	50,3 cm ²
Oil volume per 1 mm stroke	V_{Oil}	5,0 cm ³
Adjustable air gap (each side)	s	0,75 – 1,5 mm
Lining type		sinter
Lining surface	A_L	163 cm ²
Max. lining wear	s_L	8 mm
Nominal friction coefficient	μ	0.4
Disc thickness	b	20 – 40 mm
Min. disc diameter	$\varnothing D_{min}$	500 mm
Max. disc diameter	$\varnothing D_{max}$	1600 mm
Floating range on guidance pins	r	-5 / +10 mm
Temperature range (for lower temperatures please contact us)	T	-20°C to 70°C
Weight	m	85 kg

Example for mounting

Y = 90 +10/-5

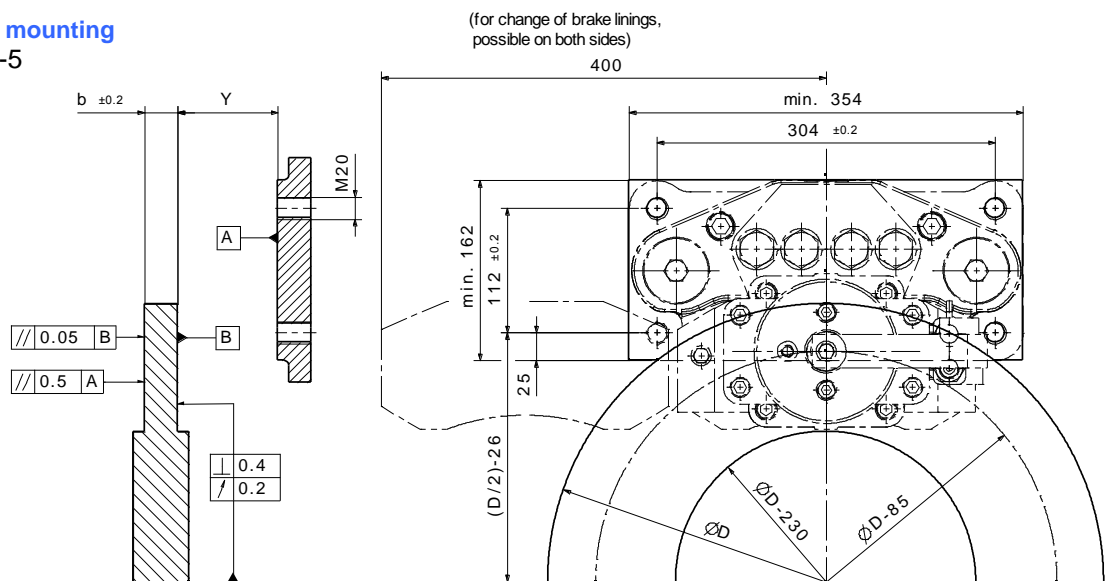

Calculation of Braking Torque

$$M_{Br} = F_{Br} \cdot \frac{D_1}{2} = 2 \cdot F_c \cdot \mu \cdot \frac{D_1}{2} = F_c \cdot \mu \cdot D_1$$

Clamping Force F_c [kN]	75-1	75-2	75-3	75-4	75-5	75-6
F_c (s = 0,75 mm)	18,1	21,6	24,6	29,1	42,8	48,6
F_c (s = 1,00 mm)	17,9	20,7	23,9	27,6	41,0	47,3
F_c (s = 1,25 mm)	17,7	19,9	23,1	26,1	39,1	46,0
F_c (s = 1,50 mm)	17,6	19,0	22,4	24,6	37,0	44,4
F_c (brake released)	21,0	26,0	30,0	37,0	56,0	61,0
Release pressure p [bar]	45	55	65	80	120	135
Max. operating pressure p_{max} [bar]	85	85	110	110	150	175