

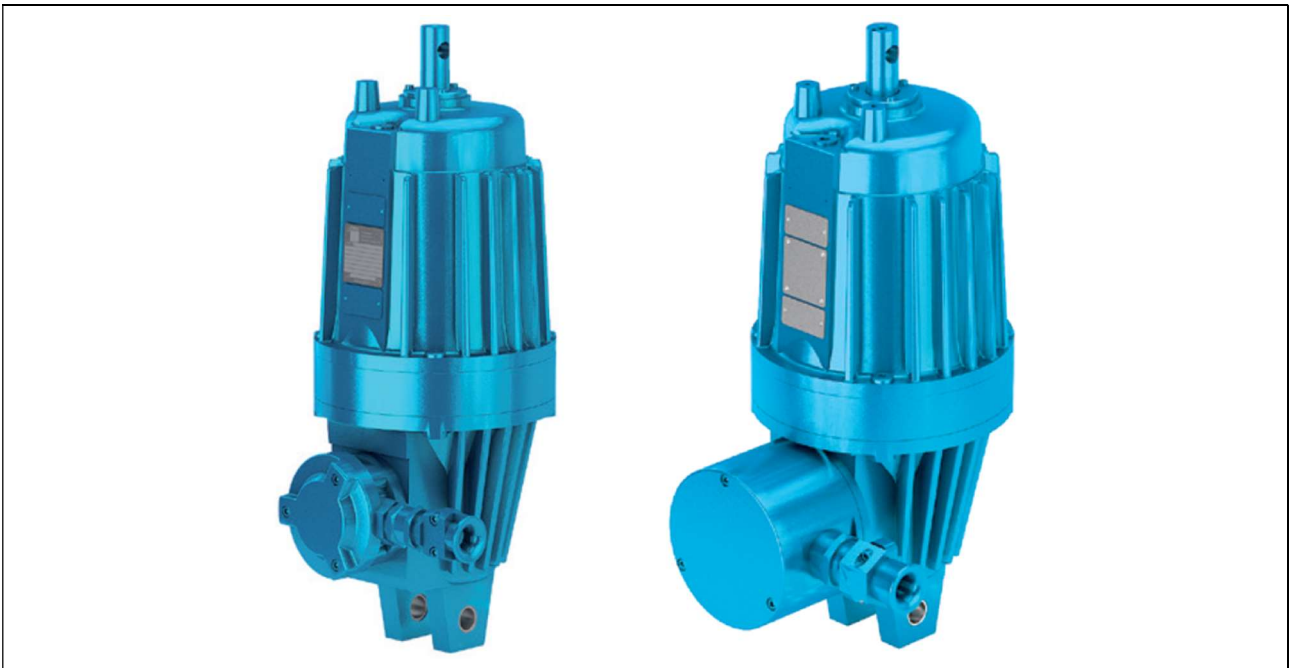

Assembly manual



General designation

Electro-hydraulic lifting thruster ELDRO® EdEx

Type designation

**Series EdEx 32 to EdEx 320 (three-phase version)
Explosion-proof design**

Date:

03.2020

Table of contents

1	General.....	6
1.1	Information about this assembly manual	6
1.2	Manufacturer.....	6
1.3	Validity.....	7
1.4	Further applicable documents.....	7
1.5	Formal information about this assembly manual	7
1.6	Format conventions	8
1.7	Structure of warning notices	9
1.8	Terms and abbreviations.....	10
2	Safety	12
2.1	General	12
2.1.1	For use in potentially explosive areas	13
2.2	Intended use	14
2.3	Unintended use	16
2.4	Staff qualifications	16
2.4.1	Qualified personnel	17
2.4.2	Qualified electrician	17
2.4.3	Maintenance staff.....	18
2.4.4	Authorised personnel	18
2.4.5	Qualified person	18
2.4.6	Responsible staff.....	19
2.5	Personal protective equipment.....	19
2.6	Electrical equipment	20
2.7	Process media.....	21
2.8	Modifications	21
2.9	Spare and wear parts.....	21
3	Technical data	22
3.1	Thruster identification	22
3.2	Explosion protection identification	23
3.2.1	EdEx identification.....	23
3.3	Specifications on the type plate	24
3.4	Specifications on the test plate	25
3.5	Characteristics	26
3.5.1	Short lift thrusters	26
3.5.2	Long lift thrusters.....	28
3.5.3	Setting times.....	30

3.6	Dimensions	31
3.6.1	Type EdEx	31
3.6.2	Type EdEx-HV	32
3.7	Electrical system	33
3.7.1	Voltage and frequency	33
3.8	Operating fluid	33
3.9	Airborne sound emissions	34
3.10	Operating conditions	34
3.10.1	Ambient temperature	34
3.10.2	Air humidity	34
3.10.3	Aggressive ambient conditions	34
3.10.4	Installation height	34
4	Functional description	35
4.1	Mechanical layout	36
4.2	Electrical equipment	37
4.2.1	Motor	37
4.2.2	Operating modes	37
4.2.3	Junction box	37
4.3	Electrical and mechanical additional equipment	38
4.3.1	Lift, lowering or throttle valve (H, S, D)	38
4.3.2	Brake spring – C-spring	38
4.3.3	Regulating spring – R-spring	38
4.4	Function sequence	39
5	Transport and storage	40
5.1	Transport	40
5.1.1	Transport sketch	41
5.2	Storage	42
6	Assembly and installation	43
6.1	Assembly	43
6.1.1	Permissible installation positions	45
6.1.2	Installing the EdEx thruster	45
6.2	Electrical connection	47
6.2.1	Junction box and terminal diagram	49
6.2.2	Earthing conductor connection	51
6.2.3	Power supply connection	51
6.3	Adjusting the valves	53
6.3.1	Installation location of the regulating screw	54
6.3.2	Changing the set time and the reset time	55
6.4	Completing assembly	55
7	Notes on operation	56

7.1	Safety instructions	56
7.2	Tests before commissioning	57
7.2.1	Operating conditions	57
7.2.2	Order parameters	58
7.2.3	Technical parameters.....	58
7.3	Operating modes	58
8	Help with malfunctions	59
8.1	Faults and troubleshooting	59
9	Maintenance	61
9.1	Safety instructions	61
9.2	Maintenance tasks	62
9.2.1	Operating fluid	63
9.2.2	Intervals for renewing the operating fluid	64
9.2.3	Checking the operating fluid.....	64
9.2.4	Seals	65
9.2.5	Changing the operating fluid	66
9.3	Maintenance schedule	67
9.3.1	Classification	68
10	Disassembly	69
10.1	Safety instructions	69
10.2	Disconnecting the electrical connections	70
10.3	Removal	70
11	Disposal	72
11.1	Disposal consideration	72
12	Lists	73
12.1	Index of figures	73
12.2	Index of tables	73
13	Appendix	74
13.1	EU Declaration of Conformity	74
13.2	Further applicable documents	75

1 General

1.1 Information about this assembly manual



1 General

1.1 Information about this assembly manual

This assembly manual was prepared according to the principles of technical editing and the minimum legal requirements of directive 2006/42/EU are used as a basis. The assembly manual enables the safe and efficient operation of the ELDRO® EdEx electro-hydraulic lifting thruster (subsequently referred to as EdEx thruster).

This assembly manual is part of the EdEx thruster and must be kept in its immediate vicinity and accessible to staff at all times.

The staff must have read this assembly manual carefully and understood it before starting any work.

Version	Description	Date	Author
V1.0	First draft of the test version for DEKRA EXAM GmbH	21/10/2019	CE Design
V1.1	First draft	27/03/2020	CE Design
V1.2	Declaration of conformity + footer	14/05/2020	EMG

1.2 Manufacturer

EMG Automation GmbH
Werk Oschersleben
Am Pfefferbach 20
39387 Oschersleben / Germany

Phone +49 3949 928 500
Fax +49 3949 928 513

Email info@emg-automation.com
Website www.emg-automation.com

1.3 Validity

This manual corresponds to the technical state of the EdEx thruster at the time of issue. The contents of this manual are not contractually binding but are provided as information.

EMG Automation GmbH reserves the right to make content and technical changes compared to this manual without having to specify these. EMG Automation GmbH cannot be held responsible for any inaccuracies or incorrect specifications in this manual, which are caused by content and technical changes after delivering this EdEx thruster, as there is no obligation to update this manual continually.

1.4 Further applicable documents

All documents listed in the appendix (further applicable documents) to this assembly manual must be observed.

1.5 Formal information about this assembly manual

Document version: V 1.1

Date: 03.2020





© Copyright, 2020

All rights reserved.

Reprinting, including excerpts, is only permissible with the approval of EMG Automation GmbH.

1.6 Format conventions

Table 1: Format conventions

Format	Meaning
1. Action	Action step with a sequence
▪	Action step / user instruction
–	List
"ABC"	Highlighting of special terms in the text
⇒	Reference to chapters or sections of this assembly manual or to further applicable documents (e.g ⇒ Technical data chapter)
	This signal word indicates an immediate threat of danger. If this danger is not avoided, this will result in death or serious injuries.
	This signal word indicates a possible danger. If this danger is not avoided, this may result in death or serious injuries.
	This signal word indicates a possibly dangerous situation. If this dangerous situation is not avoided, this may result in minor or moderate injuries.
	This signal word indicates actions for preventing property damage. Observing this information prevents damage or destruction of the EdEx thruster.
	Supplementary information

1.7 Structure of warning notices

If observed, warning notices protect against possible personal injury and property damage and classify the extent of the danger by the signal word.

 WARNING = Signal word
Source of danger Possible consequences of non-compliance – Measures for avoidance/prohibited actions

Hazard signs

The hazard sign indicates warning information that alerts you of personal injury hazards.

Source of danger

The source of the danger indicates the cause of the hazard.

Possible consequences of non-compliance

The possible consequences when failing to observe the warning information are bruises, burns or other serious injuries.

Measures/prohibited actions

Measures / prohibited actions contains a list of instructions that must be implemented in order to avoid a hazard or that are prohibited in order to avoid a hazard.

1.8 Terms and abbreviations

The following terms and abbreviations are used in the assembly manual.

Table 2: Terms and abbreviations

Term/abbreviation	Meaning
ATEX	ATmosphere EXplosible
Brake spring (C-spring)	Cylindrical pressure spring that counteracts the hydraulic force. As a result, only the force difference on the lifting rod is effective as the actuating force.
Damping spring (D-spring)	Spring for gentle braking. This reduces the braking force by applying the brake shoes continuously until the stop value is reached. When bleeding the brake, the braking force reduces continuously from the highest value to zero (releasing the brake shoes). This function is only available in combination with the C-spring.
ED	Duty cycle
EdEx thruster	Electro-hydraulic lifting thruster in explosion-proof design that converts electrical energy into mechanical energy in a straight line movement by hydraulic means
EN	European standard
EPL	Equipment Protection Level
Highest value for additional load	Total of the forces that apply to the lifting rod head and that affect the lifting movement and setting time, e.g. friction and mass of the connection elements
Lifting valve H	Valve to reduce the lifting speed
Throttle valve D	Valves to reduce the lifting and lowering speeds
Lifting time	Time from switching the motor on until the top piston limit position is reached
Nominal operating point	Operating point that is at 1/3 of the nominal lift
Nominal lift	Maximum path that the extending lifting rod can take
Nominal reset force	Minimum force at the nominal operating point for a machine with reset spring C
Nominal actuating force	Usable hydraulic force on the lifting rod head for a machine without reset spring c
Regulation braking	Braking to regulate three-phase motors to low speeds, virtually independent of the load. A pump wheel with optimum adjustment determines the hydraulic force with the nominal reset force. Thrusters for regulation braking are equipped with reset spring C and damping spring D.
Regulating spring (R-spring)	See damping spring
Reset spring	See brake spring
Lowering valve S	Valve to reduce the lowering speed

Table 2: Terms and abbreviations

Term/abbreviation	Meaning
Lowering time	Time from switching the motor off until the bottom piston limit position is reached.

2 Safety

EdEx thrusters are reliable electro-hydraulic machines for use in industrial systems. They are state of the art.

The generally applicable regulations and other binding directives regarding health and safety, accident prevention and environmental protection must be adhered to.

The following safety regulations must be adhered to before beginning any work on EdEx thrusters:

- Ensure that the industrial system is shut down
- De-energise the system
- Safeguard the system to prevent it being switched on again
- Test to ensure a de-energised state
- Cover or isolate adjacent live parts

2.1 General

- The EdEx thruster must be able to swivel, transverse forces must not act on the lifting rod
- Keep the terminal box clean and close it tightly
- Ensure that the seals are correctly seated and undamaged
- Check the tightness and correct installation of the cable entry
- The intervals for renewing the operating fluid must be observed.
- The brake must not have its own spring or weight load if the EdEx thruster has an integrated brake spring (⇒type plate, designation C...).
- If the EdEx thruster is retrospectively painted, it is essential to protect the lifting rod and the sealing system to prevent leakage
- The maximum permissible layer thickness (subsequent coating) according to ATEX approval must not be exceeded (if necessary, consult the manufacturer EMG Automation GmbH).
- Regular cleaning must be carried out to prevent dust deposits with a layer thickness of more than 5 mm.
- The EdEx thrusters may only come into contact with substances that do not impair the properties of the thruster materials.

2.1.1 For use in potentially explosive areas

- It is essential to observe the applicable regulations, plant-specific provisions and the requirements for the test personnel.
- Installation, commissioning and recurring tests may only be carried out by suitably qualified personnel (competent person).
- Compliance with the following important explosion protection characteristics must be evident from the marking on the product:
 - G = Gas, D = Dust; M = Mining
 - Thruster category 1,2,3 in the 3 zone areas
 - Gas characteristic values: Temperature class (T1..T6),
Explosion group (II A,B,C)
 - Dust characteristic values: Explosion group (III A, B: not
conductive; C: conductive);
surface temperature,
glow and ignition temperature
- For work such as assembly, electrical connection, repair or opening the housing, it must be ensured that
 - no explosive atmosphere is present.
 - no electrical voltage is present.
 - inadvertent switching on is not possible.
- Dust deposits on EdEx thrusters must be avoided so no dangerous temperature increase arises on the surface.
- Clean non-conductive parts (e.g. plastic) using only a damp cloth
- Ensure that all technical and organisational protective measures are fulfilled and their function/effect is tested.
- Modifications to the EdEx thrusters are not permitted and can cause an explosion hazard (ignition).
- The contents of the EU type examination certificate must be observed. If there is an X after the number on the EC type examination certificate, special conditions or deviations from the standard conditions apply. These special notes must therefore be checked in the certificate.
- Before any activities (e.g. assembly) are carried out in potentially explosive areas, the operating company must issue approval for the work.

- The specification of the maximum surface temperature is only valid for dust deposits up to a maximum of 5 mm.
- Clean only using a damp cloth (ESD danger)
- For dusts of group IIIA/IIIB/IIIC it is necessary to prevent electrostatic charges on the housing surface, which can lead to propagating brush discharges, through suitable measures. These EdEx thrusters must not be exposed to highly charging processes.
- Fixing screws of the end shield must have a yield strength of 640 Nm² (quality 8.8).
- Additional non-conductive (colour) coatings must not exceed the total coating thickness for IIA/B by more than 2 mm and for IIC by more than 0.2 mm.
- The use of contrasting colours makes it easier to detect dust deposits.
- When coating, care must be taken to ensure chemical resistance to the ambient conditions.

2.2 Intended use

The EdEx thruster is partly completed machinery and must be connected to other parts to form a complete machine. The safety of this complete machine must prevent hazards caused by controlling and operating the system.

EdEx thrusters are used to apply straight work movements using electro-hydraulics. In drive technology, drives are braked or stopped using brakes with electro-hydraulic actuation thrusters (lifting thrusters). EdEx thrusters are mainly used in drive technology to bleed drum and disc brakes (brake bleeder).

However, EdEx thrusters can also be used in many other areas of production, transport technology, warehousing and handling technology, wherever a straight work movement is required and a single drive is wanted.

Applications as an actuator include actuating

- Valves
- Couplings
- Slides
- Throttle valves
- Locking thrusters

EdEx thrusters are suitable for use in the following potentially explosive areas.

- Gases (G) in zones 1 and 2
- Dust (D) in zones 21 and 22
- Mining (M)

Table 3: Use in zones in potentially explosive areas

Thruster category	Thruster protection level (EPL)	Zone		
		0 (20)	1 (21)	2 (22)
1 G (D)	Ga (Da)	X	X	X
2 G (D)	Gb (Db)	–	X	X
3 G (D)	Gc (Dc)	–	–	X

Intended use also includes adhering to the assembly, operating and maintenance procedures described in this assembly manual.

The technical data and the specifications for terminal assignments are specified on the type plate and in the manual, and must be adhered to.

EdEx thrusters may only be operated in the permissible installation position and operating mode. Only this intended use is permissible. Any other use is prohibited.

2.3 Unintended use

Reasonably foreseeable misuse

- Use of the EdEx thrusters in potentially explosive areas for which the EdEx thrusters are not suitable

Any unintended use or impermissible operating modes constitutes misuse of the EdEx thrusters. For safety reasons, all applications not listed in the intended use section are strictly prohibited by the manufacturer.

All applications as an actuator always require confirmation from the manufacturer. Applications as actuators that cause the power supply for retracting the lifting rod to fail are not permitted due to the associated risk of accidents.

2.4 Staff qualifications

Authorised and qualified staff must be deployed for intended use of the EdEx thrusters. The scope of responsibility, authority and supervision of personnel must be precisely stipulated by the operating company.

Qualified staff are people who, due to their training, experience and instruction, as well as their knowledge of applicable standards, regulations, accident prevention regulations and operating conditions, are authorised by the person responsible for system safety to perform the relevant required tasks and are thereby able to identify and avoid possible hazards.

Work on or with EdEx thrusters may only be performed by trained and qualified staff who have received system-specific instructions, who are authorised to do so and who have special knowledge and experience within the corresponding field.

Contact EMG Automation GmbH if the required staff qualifications are unclear.

2.4.1 Qualified personnel

EdEx thrusters may only be transported, set up, connected, operated and maintained by specialists. All work must be performed with the intended, intact tools, equipment, test equipment and consumables, and must be inspected by the specialists responsible. The specialists must be authorised to perform the required tasks by the person responsible for the industrial system's safety.

Specialists include industrial mechanics or people who have comparable, country-specific training and who have the following knowledge:

- Knowledge and experience in transporting, storing, assembling and disposing of the EdEx thrusters
- Knowledge and experience of the electrical, mechanical and hydraulic equipment on the components of the EdEx thrusters
- Functionality of the EdEx thrusters
- Retrofitting and professional adjustment of EdEx thrusters
- Hazards on the system and suitable safety measures
- Expert knowledge of explosion protection

2.4.2 Qualified electrician

Electrical specialists include electricians who,

- due to their technical training, knowledge, and experience, as well as knowledge of applicable standards and regulations, are capable of carrying out work on electrical systems
- have been commissioned and trained by the operating company to perform work on electrical systems and equipment on the EdEx thrusters
- are familiar with the EdEx thruster functions
- can detect and avoid possible hazards by taking suitable safety measures.
- Expert knowledge of explosion protection

2.4.3 Maintenance staff

Maintenance staff include industrial mechanics or people who have comparable, country-specific training. Maintenance staff are people who have been commissioned by the operating company to maintain the system and who have the following knowledge:

- Knowledge and experience of the electrical, mechanical and hydraulic equipment on the components of the EdEx thrusters
- EdEx thruster functions and maintenance points
- Hazards on the EdEx thrusters and suitable safety measures
- Lubricating, cleaning, preserving, topping up to replacing consumables
- Expert knowledge of explosion protection
- Replacing wear parts
- Retrofitting and professional adjustment of EdEx thrusters

2.4.4 Authorised personnel

Authorised personnel are persons (usually maintenance personnel) who have received additional training from the manufacturer EMG Automation GmbH in handling the EdEx thrusters. This allows you to carry out additional and complex repairs. The description of these activities is not included in the scope of this instruction manual. Authorised personnel possess expert knowledge of explosion protection.

2.4.5 Qualified person

A qualified person is a person who has the specialist knowledge required to check the work equipment (e.g. tools, devices, machines or systems) due to their professional training, work experience and their near-term job. They are not subject to any technical orders during their checking work and may not be disadvantaged by this work. The competent person possess expert knowledge of explosion protection.

2.4.6 Responsible staff

The following table provides you with information on the staff qualifications that are the prerequisites for the corresponding tasks. Only people who have the corresponding qualification may perform these tasks.

Table 4: Responsible staff

Task	Responsible staff			Manufacturer or personnel authorised by the manufacturer
	Qualified personnel	Qualified electrician	Maintenance staff	
Transport	x			
Assembly	x			
Electrical installation		x		
Starting up	x			
Shutting down	x			
Fault rectification	x		x	x
Electrical fault rectification		x		x
Maintenance	x		x	
Repairs	x			x
Electrical repairs		x		x
Dismantling	x			
Storage	x			
Disposal	x			x

Contact EMG Automation GmbH if the required staff responsibilities are unclear.

2.5 Personal protective equipment

The operating company must prescribe personal protective equipment according to the danger risk. Personal protective equipment includes the following among others:

- Safety shoes, work clothing, protective clothing if required
- Protective gloves
- Hard hat
- Safety goggles

This list of personal protective equipment is not exhaustive.

2.6 Electrical equipment

- Work on electrical equipment must be carried out exclusively by electricians.
- When performing any work on electrical components, the five safety rules must be adhered to:
 - Disconnect from the electrical supply
 - Safeguard to prevent a restart
 - Test to ensure a de-energised state
 - Earth and short-circuit
 - Cover or isolate adjacent live parts
- Perform regular checks for insulation and housing damage.
- Never operate the EdEx thruster with electrical connections that are faulty or not ready for operation.
- If there are power supply faults, the system must be switched off immediately.
- Before any work on electrical components, switch the mains disconnection thruster off and secure it to prevent it being switched on again.
- It is essential to observe the inspection and maintenance intervals specified by the manufacturer for electrical components.
- All touchable, conductive parts of the system are connected to the external earthing conductor system. The earthing conductor system must be inspected after performing maintenance work (e.g. replacing components).
- Some equipment (e.g. mains power units, servo controllers, converters) with electrical intermediate circuits may store residual voltage for a certain time after being disconnected. Before starting work on these systems, check that they are de-energised.

- Check the voltage supply using the data on the type plate and then establish the electrical connection according to the terminal diagram on the inside of the terminal box frame. The phase sequence is arbitrary. The earthing must maintain an earth leakage resistance of $< 10^6 \Omega$. The connection to the earthing screw must be established with a suitable cable lug (minimum cross section 4 mm²)

2.7 Process media

- The instructions on the manufacturer's material safety data sheets must be followed.
- Contact with eyes or the skin should be avoided.
- Avoid inhaling vapours or mist.
- Soak up any spilled or leaking process media immediately with a binding agent and dispose of it properly.
- Keep containers with flammable substances and compressed, liquefied gases away from sources of heat.

2.8 Modifications

Changes, additions and modifications to EdEx components that could impair safety or function are not permitted.

2.9 Spare and wear parts

The use of spare and wear parts from third-party manufacturers may lead to risks. Only original parts or spare and wearing parts approved by the manufacturer may be used.



For information regarding spare parts orders for EdEx types that can no longer be supplied, see the "Ordering notes for replacement thrusters".

3 Technical data

3.1 Thruster identification



3 Technical data

3.1 Thruster identification

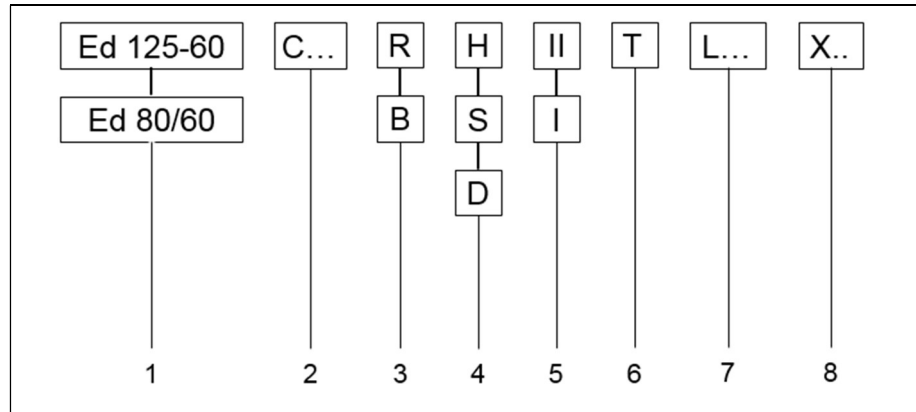

Figure 1: Thruster identification

- 1 EdEx type
- 2 Brake/reset spring
- 3 Regulating spring (R-spring)
- 4 H Lifting valve
S Lowering valve
D Throttle valve
- 5 Identification of installation position
- 6 Corrosion protection class
- 7 Sensors, limit switches
- 8 Adaptors, special series

3.2 Explosion protection identification

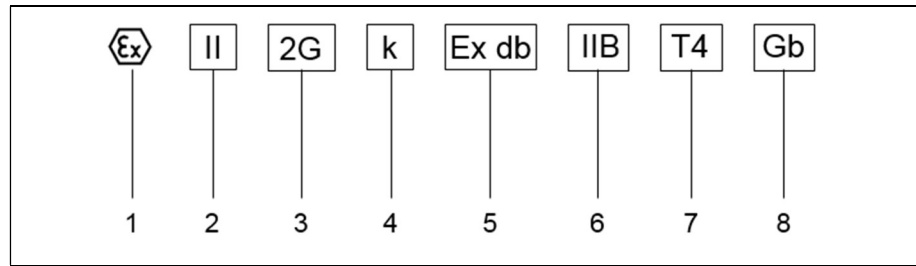

Figure 2: Explosion protection identification

- 1 EU Directive 2014/34
- 2 Thruster group
- 3 Thruster category
- 4 Ignition protection type for non-electrical thrusters "Liquid encapsulation"
- 5 Ignition protection type for electrical equipment "Pressure-proof encapsulation"
- 6 Explosion protection group
- 7 Temperature class
- 8 EPL mark (thruster protection level)

3.2.1 EdEx identification

Table 5: EdEx identification

Underground (mining)		Ex	I	M2	k	Ex db I			Mb
						Ex db eb I			
Above ground	Gas	Ex	II	2G	k	Ex db	IIC	T4	Gb
							IIB	T5	
	Dust		II	2D	k	Ex tb IIIC	T130 °C	Db	
							T125 °C		
					T95 °C				

3 Technical data

3.3 Specifications on the type plate



3.3 Specifications on the type plate

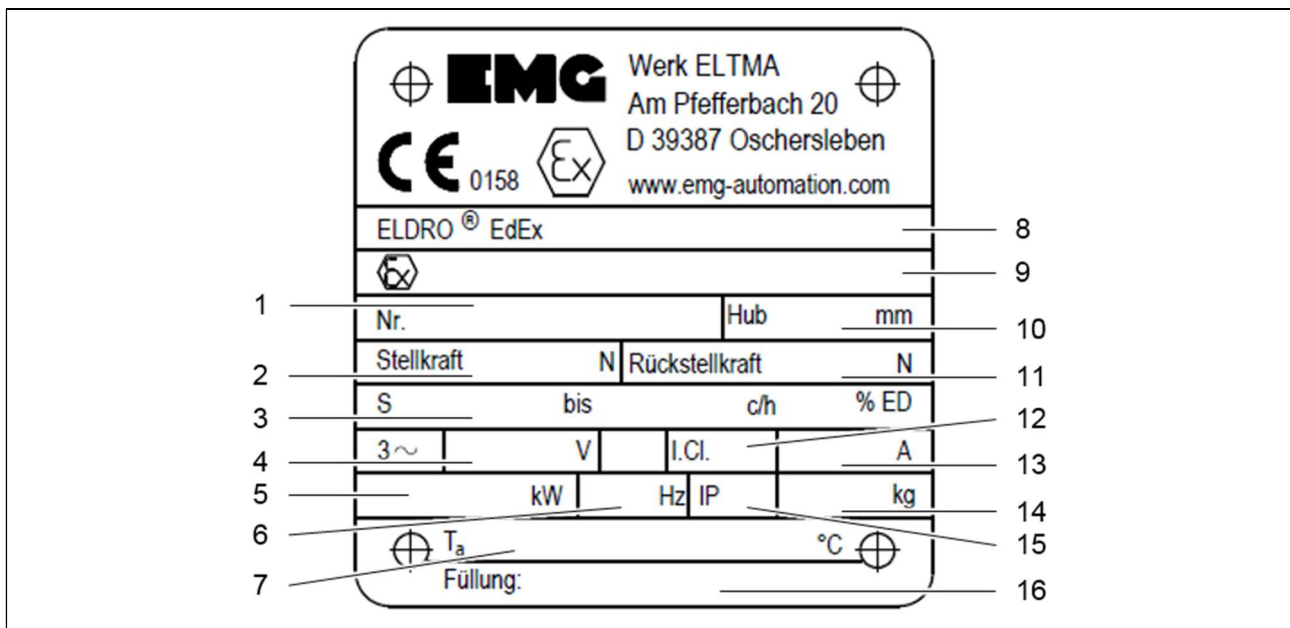

Figure 3: Type plate

1	Serial number, date of manufacture	9	Explosion protection identification
2	Actuating force in N	10	Lifting path in mm
3	Operating mode S, switching / h with duty cycle in %	11	Reset force in N
4	Voltage	12	ISO class
5	Power consumption in kW	13	Current consumption in A
6	Frequency in Hz	14	Weight
7	Temperature range	15	Protection category IP
8	Thruster type	16	Operating fluid

3.4 Specifications on the test plate

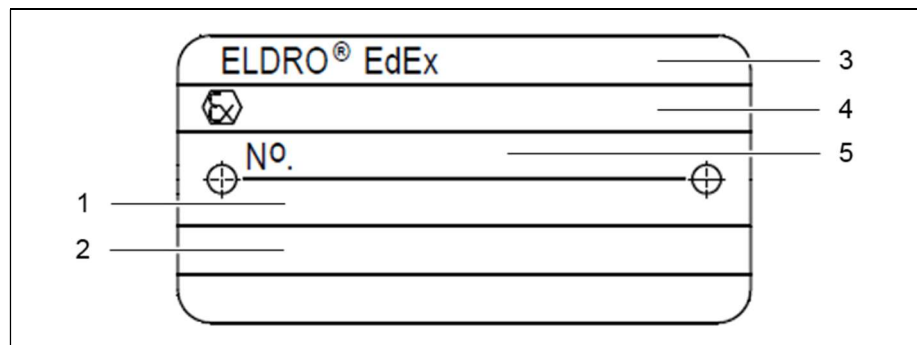

Figure 4: Test plate

- 1 EU type examination certificate
- 2 IECEx certificate number
- 3 Thruster type
- 4 Explosion protection identification
- 5 Serial number, date of manufacture

3.5 Characteristics

3.5.1 Short lift thrusters

General characteristics



All technical data are mean values relating to +20 °C thruster temperature.

Table 6: Characteristics – short lift thrusters EdEx 32/50-EdEx 150/75

EdEx type	EdEx								
	32/50	50/50	80/60	80/75	125/60	125/60	125/75	150/60	150/75
Nominal actuating force [N]	320	500	800	800	1,250	1,250	1,250	1,500	1,500
Nominal lift [mm]	50	50	60	75	60	60	75	60	75
Power consumption ^{2) 3)} [W]	150	180	220	220	250	250	250	360	360
Current at 400 V AC 3-ph ^{2) 3)} [A]	0.30	0.38	0.48	0.48	0.52	0.52	0.52	0.63	0.63
Fill quantity [l]	2.4	2.4	3.9	3.9	3.9	3.9	3.9	3.9	3.9
Weight [kg]	32.0	32.0	45.0	45.0	45.0	45.0	45.0	20.6	20.6

Table 7: Characteristics – short lift thrusters EdEx 200/60-EdEx 320/100

EdEx type	EdEx								
	200/60	250/60	320/100						
Nominal actuating force [N]	2,000	2,500	3,200						
Nominal lift [mm]	60	60	100						
Power consumption ^{2) 3)} [W]	320	360	550						
Current at 400 V AC 3-ph ^{2) 3)} [A]	0.64	0.69	0.90						
Fill quantity [l]	7.4	7.4	10.8						
Weight [kg]	65.0	65.0	80.0						

- 1) Values for thrusters with integrated brake/reset spring
- 2) Values at operating temperature; with switch-on processes below 0 °C thruster temperature the current consumption is approx. 2 times the current consumption at a thruster temperature > +20 °C
- 3) Hydrotherm 46 M

C-spring characteristics



All technical data are mean values relating to +20 °C thruster temperature.

Table 8: C-spring characteristics – short lift thrusters EdEx 32/50-EdEx 125/75

EdEx type	EdEx								
	32/50	32/50	50/50	50/50	50/50	80/60	80/60	80/75	125/60
C-spring	C18	C32	C18	C32	C50	C45	C80	–	C45
Brake/reset force ¹⁾ , min. [N]	170	370	170	370	540	460	740	–	460
Brake/reset force ¹⁾ , max. [N]	215	440	215	440	655	570	1,080	–	570

Table 9: C-spring characteristics – short lift thrusters EdEx 125/60-EdEx 200/60

EdEx type	EdEx								
	125/60	125/60	125/75	150/60	150/60	150/60	150/75	200/60	200/60
C-spring	C80	C125	–	C45	C80	C125	–	C45	C70
Brake/reset force ¹⁾ , min. [N]	740	1,200	–	460	740	1,200	–	460	650
Brake/reset force ¹⁾ , max. [N]	1,080	1,650	–	570	1,080	1,650	–	570	910

Table 10: C-spring characteristics – short lift thrusters EdEx 200/60-EdEx 320/100

EdEx type	EdEx								
	200/60	200/60	250/60	250/60	250/60	250/60	320/100	320/100	320/100
C-spring	C130	C200	C45	C70	C130	C200	C70	C250	C320
Brake/reset force ¹⁾ , min. [N]	1,250	1,900	460	650	1,250	1,900	530	2,080	2,610
Brake/reset force ¹⁾ , max. [N]	1,600	2,510	570	910	1,600	2,510	940	3,700	4,640

3.5.2 Long lift thrusters

General characteristics



All technical data are mean values relating to +20 °C thruster temperature.

Table 11: Characteristics – long lift thrusters EdEx 80/160-EdEx 320/120

EdEx type	EdEx							
	80/160	125/160	150/160	200/160	250/160	320/120		
Nominal actuating force [N]	800	1,250	1,500	2,000	2,500	3,200		
Nominal lift [mm]	100	160	160	160	160	120		
Power consumption ^{2) 3)} [W]	210	250	300	310	350	310		
Current at 400 V AC 3-ph ^{2) 3)} [A]	0.48	0.52	0.57	0.64	0.66	0.64		
Fill quantity [l]	6.0	6.0	6.0	11.1	11.1	11.1		
Weight [kg]	54.0	54.0	54.0	80.0	80.0	80.0		

- 1) Values for thrusters with integrated brake/reset spring
- 2) Values at operating temperature; with switch-on processes below 0 °C thruster temperature the current consumption is approx. 2 times the current consumption at a thruster temperature > +20 °C
- 3) Hydrotherm 46 M

C-spring characteristics



All technical data are mean values relating to +20 °C thruster temperature.

Table 12: C-spring characteristics – long lift thrusters EdEx 80/160-EdEx 150/160

EdEx type	EdEx							
	80/160	80/160	125/160	125/160	125/160	150/160	150/160	150/160
C-spring	C45	C80	C45	C80	C125	C45	C80	C125
Brake/reset force ¹⁾ , min. [N]	260	350	260	350	610	260	350	610
Brake/reset force ¹⁾ , max. [N]	520	1,000	520	1,000	1,520	520	1,000	1,520

Table 13: C-spring characteristics – long lift thrusters EdEx 200/160-EdEx 250/160

EdEx type	EdEx							
	200/160	200/160	200/160	200/160	250/160	250/160	250/160	250/160
C-spring	C45	C70	C130	C200	C45	C70	C130	C200
Brake/reset force ¹⁾ , min. [N]	260	270	620	890	260	270	620	890
Brake/reset force ¹⁾ , max. [N]	520	900	1,600	2,500	520	900	1,600	2,500

Table 14: C-spring characteristics – long lift thrusters EdEx 320/120

EdEx type	EdEx							
	320/120	320/120	320/120					
C-spring	C70	C250	C320					
Brake/reset force ¹⁾ , min. [N]	260	on request	on request					
Brake/reset force ¹⁾ , max. [N]	520							

3.5.3 Setting times

The following table contains time data, the lowering and resetting movement, determined for EdEx lifting thrusters without built-in lowering valve with constant nominal weight loads at +20 °C thruster temperature.

Table 15: Time data of the lowering and resetting movement

EdEx type	Without lowering valve	With integrated lowering valve	
	Lowering time in [s]	Adjustable lowering time min. in [s]	max. in [s]
EdEx 32/50...	0.45	For data refer to delivery documents, consult with EMG Automation GmbH if necessary	
EdEx 50/50...	0.36		
EdEx 80/60...	0.48		
EdEx 80/75...	0.62		
EdEx 125/60...	0.36		
EdEx 125/75...	0.49		
EdEx 150/60...	0.34		
EdEx 150/75...	0.44		
EdEx 200/60...	0.40		
EdEx 250/60...	0.35		
EdEx 320/100...	0.60		
EdEx 80/160...	0.90	For data refer to delivery documents, consult with EMG Automation GmbH if necessary	
EdEx 125/160...	0.70		
EdEx 150/160...	0.65		
EdEx 200/160...	0.85		
EdEx 250/160...	0.80		
EdEx 320/160...	0.62		

Detailed data for the adjustable delays for installed lowering valves must be determined by the manufacturer EMG Automation GmbH through individual tests. This requires precise information regarding the operating conditions.

3.6 Dimensions

3.6.1 Type EdEx

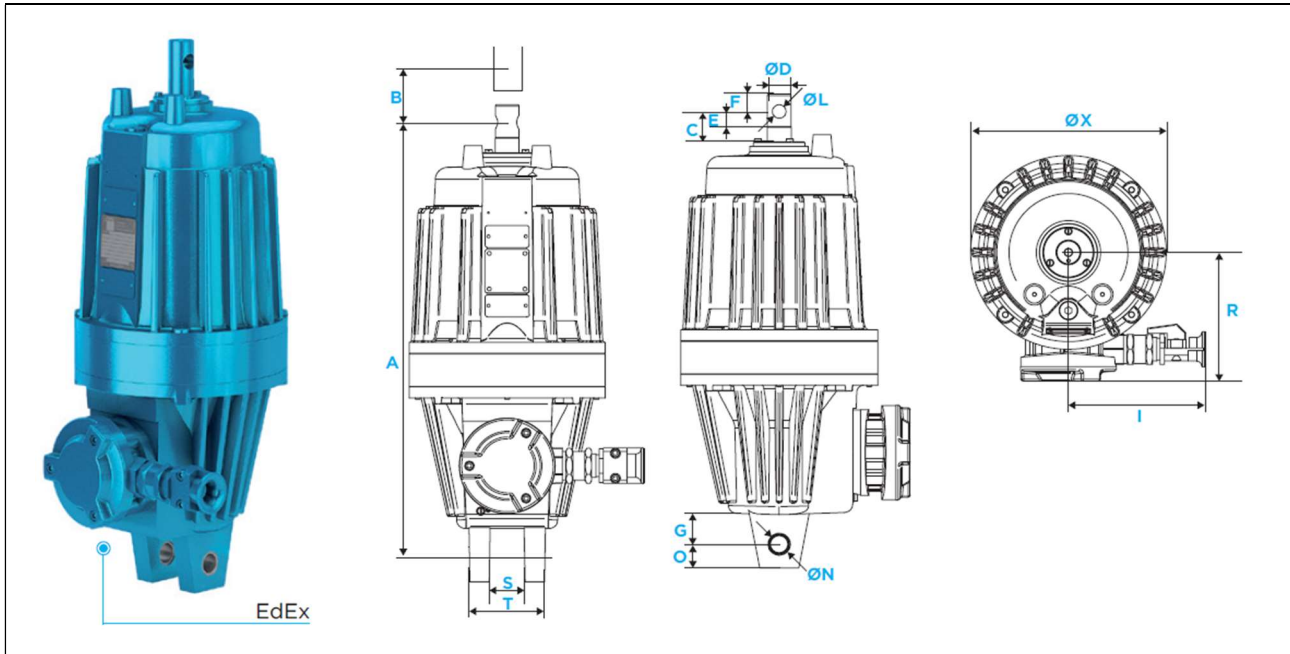

Figure 5: Type EdEx

All dimensions in the following table are in mm.

Table 16: Dimensions type EdEx

Type	A	B	C	ØD	E	F	G	I ¹⁾	ØL	ØN	O	R	S	T	ØX
EdEx 32/50 EdEx 50/50	445	50	25	21.5	16	17	26	161	12	20	21	143	40	90	200
EdEx 80/60 EdEx 125/60 EdEx 150/60	514	60	30	27.5	18	21	35	161	16	20	28	153	40	90	230
EdEx 80/160 EdEx 125/160 EdEx 150/160	630	160	32	27.5	18	21	35	161	16	20	28	153	40	90	230
EdEx 200/60 EdEx 250/60	620	60	34	35.5	24	25	35	161	20	20	30	161	40	90	275
EdEx 200/160 EdEx 250/160	720	160	34	35.5	24	25	35	161	20	20	30	161	40	90	275
EdEx 320/60 EdEx 320/120	720	160	34	35.5	24	25	35	161	20	20	30	161	40	90	275

1) Depending on cable gland

3.6.2 Type EdEx-HV

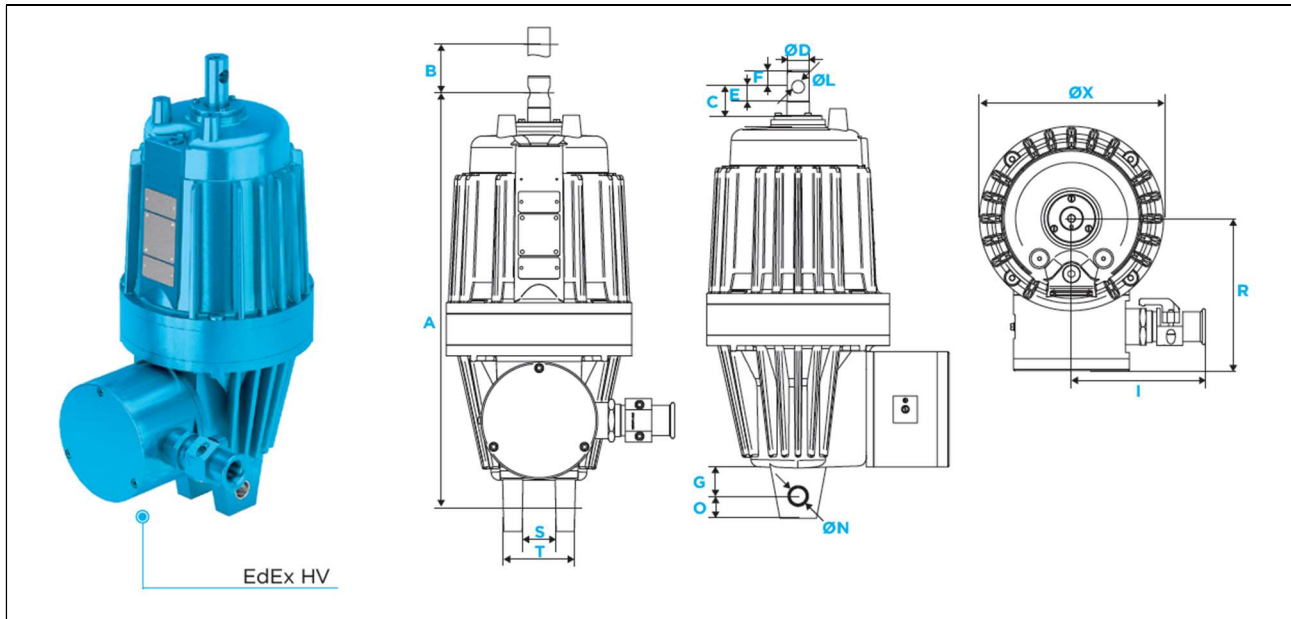

Figure 6: Type EdEx-HV

All dimensions in the following table are in mm.

Table 17: Dimensions type EdEx-HV

Type	A	B	C	Ø D	E	F	G	I ¹⁾	Ø L	Ø N	O	R	S	T	Ø X
EdEx 80/60 EdEx 125/60 EdEx 150/60	514	60	30	27.5	18	21	35	168	16	20	28	190	40	90	230
EdEx 80/160 EdEx 125/160 EdEx 150/160	630	160	32	27.5	18	21	35	168	16	20	28	190	40	90	230
EdEx 200/60 EdEx 250/60	620	60	34	35.5	24	25	35	168	20	20	30	198	40	90	275
EdEx 200/160 EdEx 250/160	720	160	34	35.5	24	25	35	168	20	20	30	198	40	90	275
EdEx 320/60 EdEx 320/120	720	160	34	35.5	24	25	35	168	20	20	30	198	40	90	275

1) Depending on cable gland

3.7 Electrical system

3.7.1 Voltage and frequency

All EdEx thrusters are switched to star (Y) when delivered.

Table 18: Electrical voltage and frequency (basic version)

Name	Values
Operating voltage	3/N/PE AC 230 up to 690 V
	3/N/PE AC 660/1140 V (HV)
Voltage tolerance, permissible	±5 %
Frequency	50 Hz or 60 Hz
Frequency tolerance, permissible	±2 %

3.8 Operating fluid

The operating fluid used depends on the ambient temperatures at the place of installation

Table 19: Operating behaviour depending on the ambient temperature

Temperature range	Operating fluid	Remark
-10 °C to +40 °C	Hydrotherm 46 M	Water glycol base
-40 °C to +40 °C	Xiameter PMX-200 Silicone Fluid 10 cst	for low temperature oil
-25 °C to +40 °C	Pentosin CHF 11S	Standard oil
-10 °C to +60 °C	Pentosin CHF 11S	for high temperature oil

Special operating fluids are required for other temperature ranges (contact the manufacturer / ⇒ General chapter, Manufacturer section).

3.9 Airborne sound emissions

The A-rated emission sound pressure level for all EdEx thrusters is 55 dB (A). This value was determined using an integrated sound pressure level measuring unit in accordance with DIN 45633 under the following measurement conditions:

- The EdEx thruster (measurement object) ran continuously.
- The measurement object was on a table around 0.8 m above the ground
- The measurement microphone was 1.6 m above the ground.
- The diagonal gap between the measurement microphone/object was 1 m.

3.10 Operating conditions

3.10.1 Ambient temperature

Explosion-proof EdEx thrusters are limited to the following ambient temperatures depending on the hydraulic medium:

Table 20: Ambient temperatures for EdEx thrusters

Temperature range	Usable EdEx thrusters
-10 °C to +40 °C	Special application
-40 °C to +40 °C	Low temperature
-25 °C to +40 °C	Standard
-10 °C to +60 °C	High temperature

3.10.2 Air humidity

With special measures, operation of EdEx thrusters is permitted up to 100 % humidity.

3.10.3 Aggressive ambient conditions

Special measures (special paint) are required for use in aggressive ambient conditions (e.g. salty ambient air).

3.10.4 Installation height

The maximum permissible installation height is 1,000 m above sea level unless otherwise specified on the type plate.

4 Functional description

The EdEx electro-hydraulic lifting thrusters are manufactured in different type groups. Due to common characteristics, the EdEx thrusters can be summarised in the following type groups.

Table 21: Classification of EdEx thrusters/type groups

Type group	Type
1	EdEx 32/50
	EdEx 50/50
2	EdEx 80/60
	EdEx 125/60
	EdEx 150/60
3	EdEx 80/160
	EdEx 125/160
	EdEx 150/160
4	EdEx 200/60
	EdEx 250/60
5	EdEx 200/160
	EdEx 250/160
6	EdEx 320/100

4 Functional description

4.1 Mechanical layout



4.1 Mechanical layout

The EdEx thruster combines all structural elements of a complete hydraulic system in one structural unit. This comprises a three-phase asynchronous motor (direct current motor in the special version), a closed hydraulic system and the work cylinder with piston and lifting rod. The hydraulic system's operating fluid is used to generate the force.

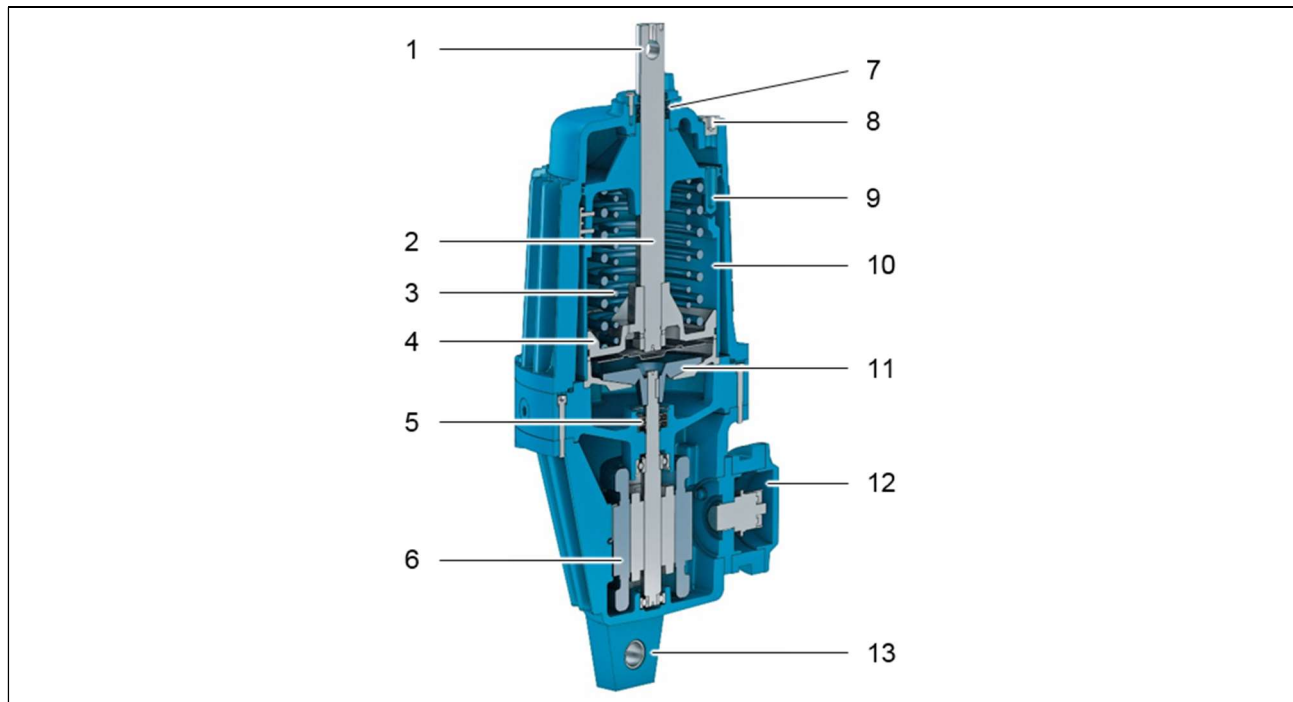

Figure 7: Design of EdEx thruster

1	Lifting rod head	8	Oil filling opening
2	Lifting rod	9	Lift/lowering valve adjustment
3	Brake spring (C-spring)	10	Hydraulic cylinder
4	Piston	11	Hydraulic pump
5	Motor shaft seal	12	Junction box
6	Two-pole three-phase asynchronous motor	13	Foot attachment
7	Sealing to the hydraulic chamber		

4.2 Electrical equipment

4.2.1 Motor

- Three-phase asynchronous motor, 2-pin
- Standard insulation according to insulation material class F

4.2.2 Operating modes

- Continuous operation S1 and intermittent operation S3 – max. 240 c/h, up to 60 % ED (duty cycle) standard

4.2.3 Junction box

- Protection category IP65, DIN VDE 0470 (IEC 529)
- Supply line connection: Screw terminal
- Protective conductor connection inside: Screw terminal, HV thruster M5
- Protective conductor connection outside: M5



All EdEx thrusters have a single voltage. Only the EdEx-HV thrusters have a double voltage of 660 V/1140 V and are wired in star connection in the factory prior to delivery.

If required, the user can reconnect the bridges (⇒ Assembly and installation chapter, Junction box and terminal diagram section) to also operate the motors in delta connection. The motor's phase sequence and therefore its direction of rotation do not matter.

4.3 Electrical and mechanical additional equipment

4.3.1 Lift, lowering or throttle valve (H, S, D)

- With a built-in lifting, lowering or throttle valve, the lifting or lowering times as well as both times together can be extended continuously. The adjustable minimum values reach 10 to 20 times the normal values.
- Built-in valves in "open position" result in an extension of the lifting and lowering times for short lift thrusters of approx. 0.4 to 1.0 seconds and for long lift thrusters of approx. 0.7 to 2.0 seconds.
- The desired lifting/lowering time is set from the outside of the thruster in an upright position.

4.3.2 Brake spring – C-spring

- Built-in C-spring to generate the braking force.
- The specified braking force of the C-spring is generated at 0 ... Maximum of the nominal lift reached (⇒ Technical data chapter)

4.3.3 Regulating spring – R-spring

- Damping of the load changes when the brake is applied
- The regulating spring is only effective in conjunction with a brake spring
- The installation dimension (A) of the thruster does not change
- When determining the operating point of the brake, the spring characteristic curve must be taken into account
- Main application: EdEx regulating brake

4.4 Function sequence

The hydraulic pump driven by the motor conveys the hydraulic medium into the space below the piston. This generates hydraulic pressure that acts outwards via the piston and lifting rod.

The piston and lifting rod move backwards after the motor is switched off either due to a force acting from the outside (brake weight, brake spring) or due to the integrated reset spring. The lifting force that is available to the user of the EdEx thruster is therefore always the difference between the generated hydraulic force and any external or internal counterforce.

The lifting and lowering times depend on both the load and the viscosity of the hydraulic medium, which is in turn affected by the ambient and operating temperatures. In the versions with lifting, lowering or throttle valves, the setting/resetting speed of the lifting rod and therefore the lifting and lowering times can be adjusted infinitely within a specific range.

If the piston is in the limit position (e.g. in continuous mode S1), the motor's power consumption reduces due to hydraulic laws. This prevents the EdEx thruster overloading and a thermal protective switch is therefore not required.

5 Transport and storage

5.1 Transport

CAUTION

The EdEx thrusters weigh between 30 and 90 kg

Risk of injury when lifting the load manually

- Use suitable lifting equipment (e.g. crane).
- Never remain below suspended loads.
- Use a transport aid (e.g. lifting carriage) with sufficient load bearing capacity.

CAUTION

Falling EdEx thruster

Risk of crushing due to a falling EdEx thruster during transport.

- Wear safety shoes

NOTICE

Do not damage the fastening eyes and the lifting rod when setting down. The lifting rod must be protected in a suitable way.

The EdEx thrusters are packed so that transport damage will not occur under normal transport conditions. The packaging requires corresponding labels.

The delivery must be checked for transport damage and completeness immediately upon receipt.

If there is clearly visible transport damage, proceed as follows:

- Do not accept the deliver or accept it with reservations.
- Note the extend of the damage on the transport documents or on the carrier's delivery note.
- Declare the faults.

Declare every fault as soon as it is discovered. Claims for damage can only be made within the legal warranty period.

5.1.1 Transport sketch

Attach a suitable load carrying thruster to the attachment point to transport using lifting gear.

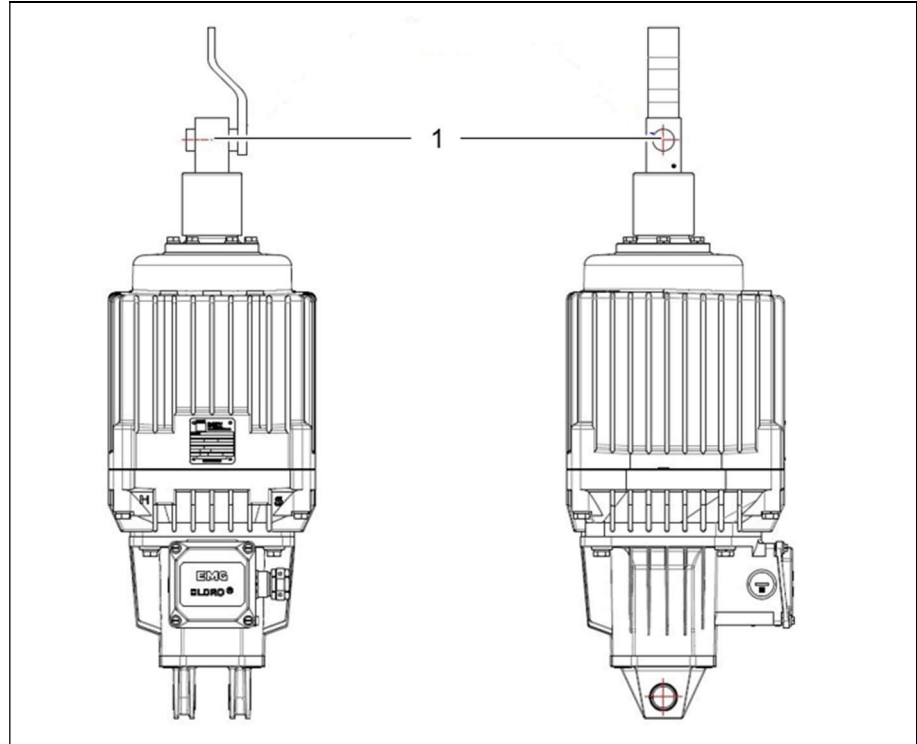

Figure 8: Attachment point

1 Attachment point

5.2 Storage

The EdEx thrusters can be transported or stored upright or lying down until commissioned. If stored for more than 6 months, we recommend storing the EdEx thrusters upright. Even though the thrusters are basically suitable for installation outdoors, we recommend taking protective measures against the effects of weather while storing.

The storage temperature must not be lower than -20 °C or higher than $+40\text{ °C}$.

NOTICE

If stored for an extended period, the regulations for storage conditions and storage periods for rubber materials and moulded items must be observed with regard to sealing. Even when installed, the seals that were stored for too long lose their elasticity and therefore their full function.

6 Assembly and installation

The following safety regulations must be adhered to before beginning any work on EdEx thrusters:

- Ensure that the industrial system is shut down
- De-energise the system
- Safeguard the system to prevent it being switched on again
- Test to ensure a de-energised state
- Earth and short-circuit
- Cover or isolate adjacent live parts

6.1 Assembly

The EdEx thruster may only be assembled by specialists (e.g. industrial mechanics/electricians) with many years of experience.

Assembly and connection of the EdEx thrusters must be carried out by persons with expert knowledge of explosion protection.

Only the intended connections may be used.

WARNING

Cylinder movements

Risk of crushing between surrounding hindrances and the cylinder or connected components.

- When assembling, ensure sufficient free space to prevent crushing.
- Take alternative measures to safeguard this hazard point.

CAUTION

The EdEx thrusters weigh between 30 and 90 kg

Risk of injury when lifting the load manually.

- Use suitable lifting equipment (e.g. crane).
- Never remain below suspended loads.
- Use a transport aid (e.g. lifting carriage) with sufficient load bearing capacity.

CAUTION

Sudden power failure or switch-off due to any C-springs, brake springs, brake weights that may be installed or due to other external influences

Risk of crushing due to the lifting rod.

- The downstream drive must be secured before removing the EdEx thrusters, because the lifting rod retracts automatically.

NOTICE

The lifting rod must not be damaged or contaminated, e.g. by paint as a result of painting the entire system. A failure to observe this will destroy the lifting rod.

NOTICE

The fastening bolts on the foot hole and the lifting rod must be secured reliably to prevent them slipping out (e.g. using cotter pins).

NOTICE

The EdEx thruster must not be subjected to any loads at an angle to its working direction. If installed upright, there must be no additional load beyond its own weight.



When replacing old EdEx thruster versions with thrusters of the current type series, it is necessary to contact the manufacturer due to the different installation dimensions (⇒ General chapter, Manufacturer section).

6.1.1 Permissible installation positions

- Vertical and intermediate positions up to 60° deviation from the vertical position (marking "II"):
 - Lifting rod acting upwards without restrictions
 - Lifting rod acting downwards is not permissible.
- Horizontal and intermediate positions up to 30° deviation from the horizontal position (marking "I"):
 - it is necessary to contact the manufacturer (⇒ General chapter, Manufacturer section).

6.1.2 Installing the EdEx thruster

Preparatory measures

The following checks must be carried out before the EdEx thruster is installed:

- The EdEx thruster must not exhibit any damage or other conspicuous changes (if necessary also check for damage to the packaging).
- The IP protection class of the EdEx thruster must correspond with the operating and environmental conditions.
- The zones are defined by the operating company.
- Check whether the thruster category corresponds to the specified zones
- Check whether the thruster category of other attachments (e.g. sensors) corresponds to the specified zones
- Check the product documentation to see whether upstream safety devices (e.g. power fuses) are required
- Specification of explosion protection requirements:
 - Safety-related characteristics for potentially explosive substances
 - Zone areas
 - Ambient temperatures

Process

To attach the EdEx thruster, there are fastening eyelets on the motor housing and holes in the lifting rod, which can be used with suitable bolts to establish the connection to the equipment to be operated (e.g. brakes).

The diameter and length of the required bolts are specified in the dimension tables (⇒Technical data chapter, Dimensions section).



When selecting or measuring the bolts (by the operating company) the required pivoting ability of the EdEx thruster must be observed.

The EdEx thruster is installed in the following steps:

- Use lifting gear to move the EdEx thruster to the installation location.
- Grease the bolt slightly in order to prevent it rusting tight.
- Insert the bolt into the foot hole.
- Insert the bolt into the thrust shackle hole.

NOTICE

Both bolt axes must be parallel as otherwise, the lifting rod jams and the thruster's free power development is not guaranteed.

- Use cotter pins or similar to secure the bolts to prevent them slipping out

6.2 Electrical connection



DANGER

Live components

Fatal electric shock or serious burns

- Work on live components may only be performed by electricians.
 - When performing any work on electrical components, the five safety rules must be adhered to:
 - 1. Disconnect from the electrical supply
 - 2. Safeguard to prevent a restart
 - 3. Test to ensure a de-energised state
 - 4. Earth and short-circuit
 - 5. Cover or isolate adjacent live parts
 - The earthing conductor must always be connected before all other cables.
 - Electrical power may only be supplied once the earthing conductor is connected.
-
- Standard requirements must be observed when connecting the EdEx thruster.
 - Before connecting, check whether the mains voltage and the mains frequency correspond to the specifications on the type plate.
 - When selecting the connection cable (temperature resistance), an excess temperature of +40 K to the ambient temperature must be taken into account.
 - For cable entries (temperature resistance) an excess temperature of +35 K to the ambient temperature must be taken into account.
 - If there is a risk of mechanical damage, the cable must be additionally protected (e.g. with a protective tube).
 - The cable diameter must be observed to ensure a tight connection in the cable entry.

- The cable gland and the screws of the housing cover must be firmly tightened to ensure that the IP protection class is maintained. Excessive tightening damages the seal and affects the IP protection class.
- If a pressure-proof cable entry with sealing ring is used, the minimum length of the connection cable must not be less than 3 m.
- The cables to be connected must be de-energised. Otherwise there is a risk of damage to the EdEx thruster and ignition of an explosive atmosphere.
- All metallic housing parts of electrical equipment and other conductive parts must be connected to the equipotential bonding system.
- The discharge from the housing of the EdEx thruster can be designed as follows:
 - external earth terminal (cross section: greater than 4 mm²)
 - secured, metallic contact with construction points which are connected to the equipotential bonding
- The external ground terminal on the housing must be connected with low resistance to the equipotential bonding of the potentially explosive area.
- No potential equalisation currents may flow between potentially explosive areas and areas that are not potentially explosive.
- The minimum cross section: 2 x 1.5 mm² or 1 x 4 mm²
- Discharging an electrostatic charge with a resistance between 0.2-1 mΩ is not considered grounding.
- Any additional sensors that may be required must be suitable and selected for the ambient conditions including the corresponding zone, and installed according to the manufacturer's specifications.

Further information is provided in the description of the power supply connection (⇒ Power supply connection section).

6.2.1 Junction box and terminal diagram

EdEx thrusters

Terminal diagram

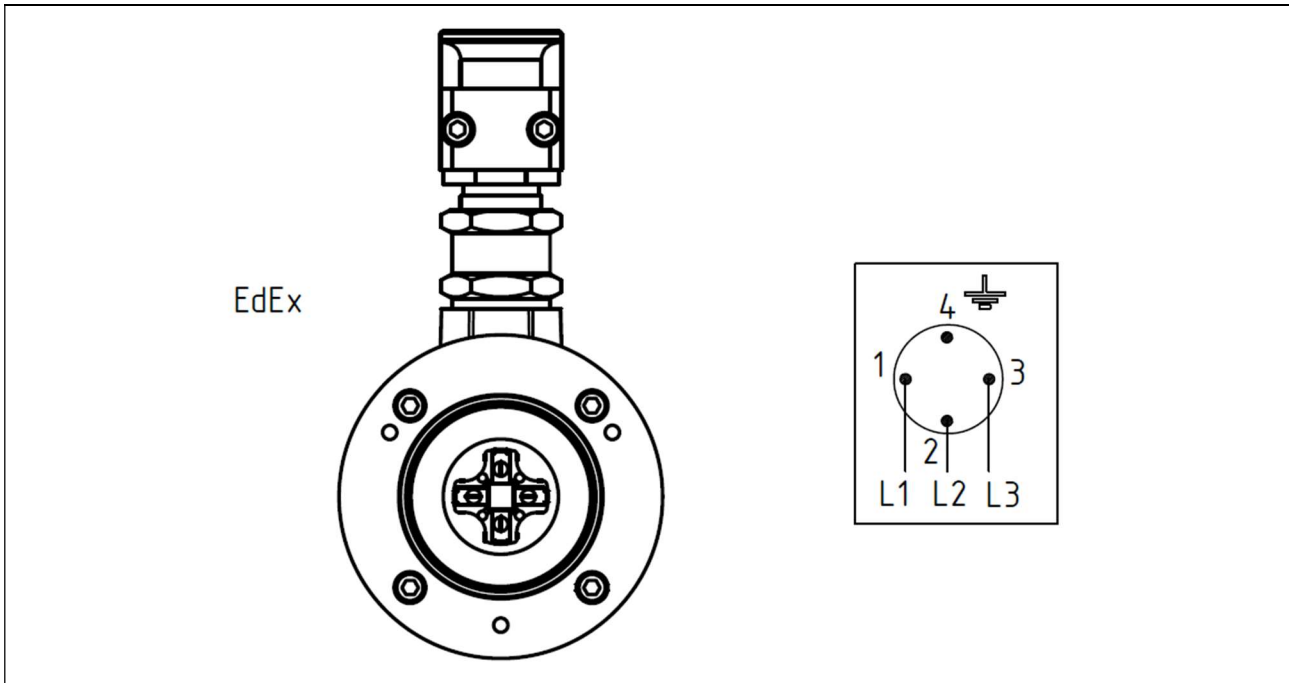

Figure 9: Terminal diagram EdEx thruster – 3-pin

- | | | | |
|---|---------------|---|-------------------------------------|
| 1 | Connection L1 | 3 | Connection L3 |
| 2 | Connection L2 | 4 | Protective conductor terminal (red) |

The torque for tightening the threaded connection is 0.8 Nm.

EdEx HV thrusters

Terminal diagram

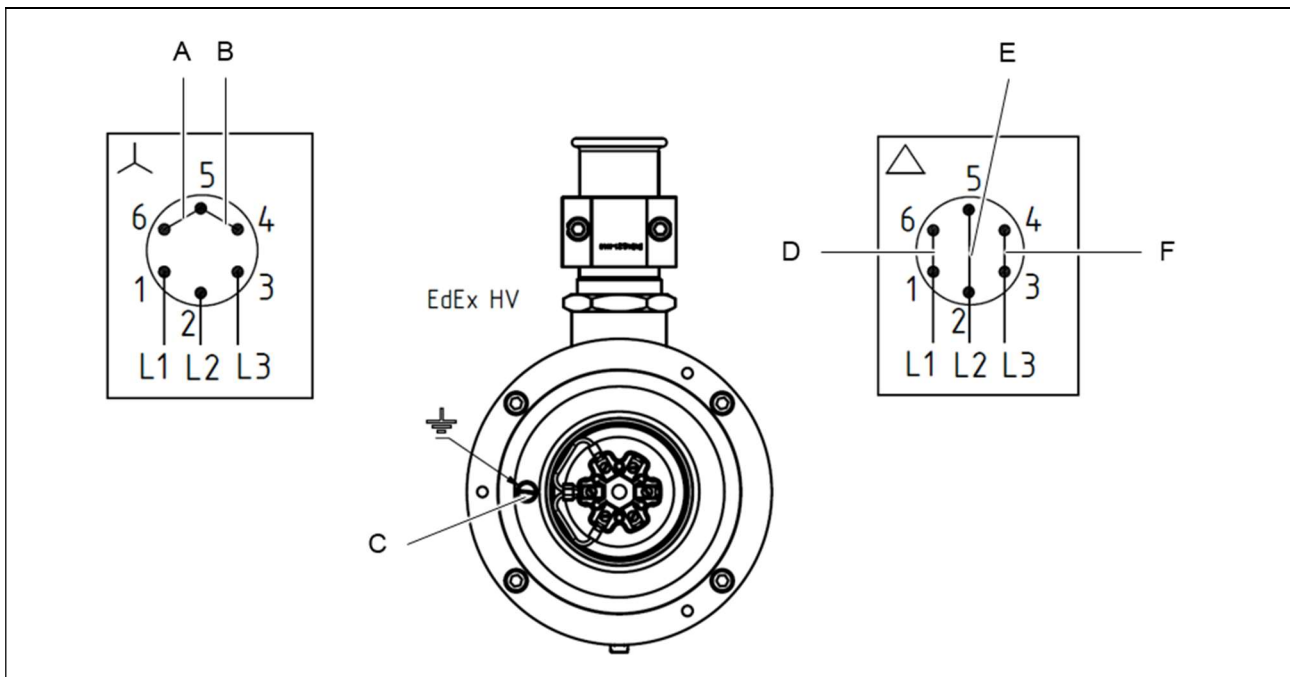

Figure 10: Terminal diagram EdEx-HV thrusters – 6-pin

- | | | | |
|---|-----------------------------|---|--|
| A | Jumper 5–6 | 1 | Connection L1 |
| B | Jumper 4-5 | 2 | Connection L2 |
| C | Earthing conductor terminal | 3 | Connection L3 |
| D | Jumper 1–6 | Δ | Delta connection |
| E | Jumper 2-5 | Y | Star connection (condition as delivered) |
| F | Jumper 3-4 | | |

The torque for tightening the threaded connection is 0.8 Nm.

6.2.2 Earthing conductor connection

NOTICE

The connection of the external protective conductor must take the swivel movement of the EdEx thruster and the surface temperature into account!

- Always connect the earthing conductor before all other cables

There is one earthing conductor connection in the junction box (⇒Junction box and terminal diagram section) and one in the immediate vicinity of the junction box on the outside of the EdEx thruster. The earthing conductor must be installed on the EdEx thruster in accordance with the applicable standards. The purpose of the earthing connector is to reduce the contact voltage in the event of coil or insulation damage to a safe amount and to switch the system off in conjunction with monitoring equipment. This can only be achieved by measuring the earthing conductor sufficiently, installing it properly and ensuring that it is intact.

6.2.3 Power supply connection

NOTICE

Before connecting, check whether the mains voltage and the mains frequency correspond to the specifications on the type plate.

Always keep the junction box clean.

Check that the sealing elements on the junction box are intact and tight.

Always lock the junction box cover after connecting.



Due to hydraulic laws, the motor's power consumption reduces when the piston has reached the limit position. This prevents overloading. A thermal protective switch is therefore not required. If a motor protection switch is used to safeguard the EdEx thrusters despite this, we recommend adjusting the thermal overcurrent trigger to 1.5 times the thruster current according to the type plate.

Electrical power may only be supplied once the earthing conductor is connected and can be provided as a fixed cable if the thruster is arranged stationary.

A pivoting arrangement requires a flexible cable. A minimum cable cross section of 1.5 mm² must be provided for all thruster sizes. The connection terminals permit a maximum cable cross section of 2.5 mm².

When selecting the cables, the ambient conditions (e.g. temperature, humidity) at the installation location must also be considered.

The length of the connecting cable must not be less than 3 m to prevent gas from passing through the cable.

During connection and integration in the system, please note that compensating currents (stray currents) could flow (e.g. as return currents). If system parts that can carry compensating currents are separated, connected or bridged, a potentially explosive atmosphere can be ignited by electrical sparks and/or arcs even with small potential differences. Furthermore, ignition is possible by heating these current paths.

Cable entry

There is a cable entry on the terminal box depending on the version:

- EdEx-Standard: M25 x 1.5 for conductor cross-section 7 x 2.5 mm²
- EdEx-HV: M32 x 1.5 for conductor cross-section 7 x 2.5 mm²
- The supply lines are always connected in accordance with the circuit diagrams on the inside of the junction box cover (⇒ Junction box and terminal diagram section).
- When selecting the connection cable (temperature resistance), an excess temperature of +40 K to the ambient temperature must be taken into account.
- For cable entries (temperature resistance) an excess temperature of +35 K to the ambient temperature must be taken into account.
- The EdEx thruster is delivered with the cable entries ("d/e/t") separately certified for the application (⇒ Table 22). The respective entry thread is marked on the EdEx thruster.

Table 22: Cable entry – cable diameter

Cable entry thread	Unarmoured cable	Armoured cable	
	Cable diameter [mm]	Cable diameter [mm]	Sheath diameter [mm]
M20 x 1.5	6.5-14.0	12.5-20.9	6.5-13.9
M25 x 1.5	11.1-20.0	18.2-26.2	11.1-19.9
M32 x 1.5	17.0-26.3	23.7-33.9	17.0-26.2
NPT 3/4"	11.1-20.0	18.2-26.2	11.1-19.9

Further information on the cable entry is provided in the assembly manual for the cable gland, which must be observed (⇒ Appendix, Further applicable documents).

6.3 Adjusting the valves



In the condition as delivered, the EdEx thrusters are set to 2 seconds of setting time and resetting time. The setting times depend on the temperature and must be adjusted when the machine is at operating temperature.

The versions with lifting and/or lowering valves enable the lifting rod's set or reset speed (setting or resetting time) to be adjusted infinitely within a specific range. The type designation specifies whether an EdEx thruster is equipped with valves (see type plate; ⇒Type designation and type key section).

Examples for the version with valves:

- Lowering valve (S): EdEx 50/6 S
- Lifting valve (H): EdEx 80/6 H
- Throttle valve (D): EdEx 121/6 D

6.3.1 Installation location of the regulating screw

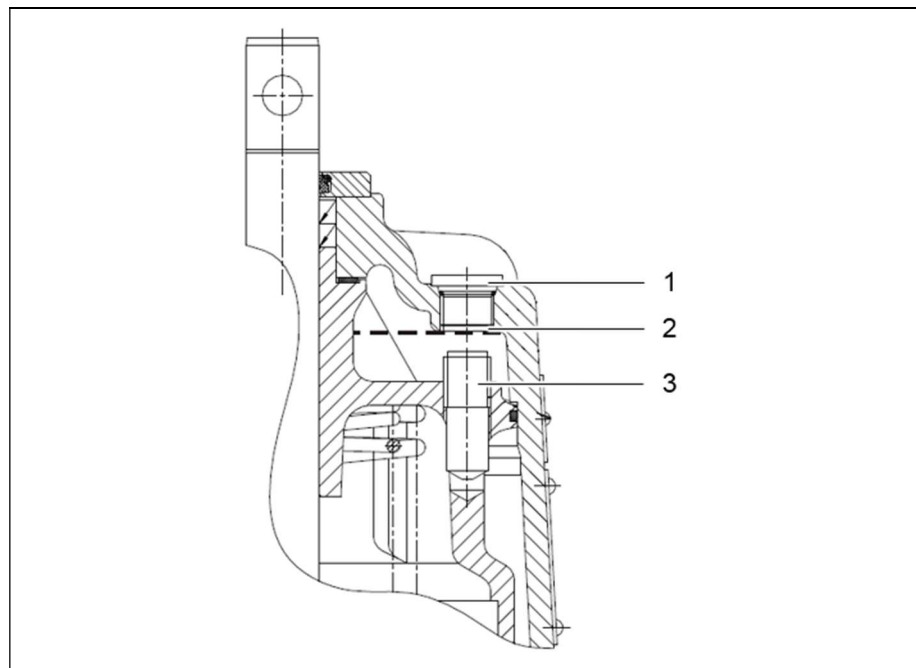

Figure 11: Regulating screw lifting/lowering/throttle valve

- 1 Screw plug (filling opening)
- 2 Filling opening
- 3 Regulating screw

6.3.2 Changing the set time and the reset time

The integrated valve system allows the stepless extension of the setting and/or resetting times. Adjustment takes place with a regulating screw. The regulating screw is located inside the thruster and is accessible after removing the outer screw plug. An Allen key (8 mm) is required as a tool. The setting times are listed in tabular form in the technical data (⇒ Technical Data chapter, Setting times section).



The setting range is 0 to 6 revolutions (0 = CLOSED = max. delay). The factory setting is 3 revolutions (starting from the zero position).

- Unscrew screw plug
- Turn the regulating screw to set the required set or reset time
- Screw in screw plug

6.4 Completing assembly

After completing assembly, check that the earthing conductor system is consistent with a resistance meter.

7 Notes on operation

7.1 Safety instructions

- Never operate the EdEx thruster with electrical connections that are faulty or not ready for operation.
- The EdEx thruster must be operated exclusively with the hydraulic medium specified on the type plate. (Depending on the hydraulic medium used, operation of the EdEx thruster is limited to the specified ambient temperatures.)
- The junction box must always be locked. Access must only be granted to authorised staff who have received corresponding training and safety briefings.
- If there are power supply faults, switch the EdEx thruster off immediately.



WARNING

EdEx thrusters can reach housing surface temperatures of up to 100 °C in continuous mode S1 or in very high switching mode S3

Risk of burns on the housing surface

- Avoid touching the housing surface during operation.
- Wear safety gloves.



WARNING

Component failure

Risk of injury due to component failure

- There is the risk of individual components breaking when operating the EdEx thruster. The lifting force failure can pose subsequent hazards.
- The operating parameters must be adhered to.
- The EdEx thruster must be installed so that no forces can be applied at an angle to the working direction.

**WARNING****Cylinder movements**

Risk of crushing between surrounding hindrances and the cylinder or connected components as a result of the cylinder retracting automatically due to the reset spring with a hydraulic pressure drop, or if the power supply is interrupted.

- Switching the motor off returns the cylinder to the limit position.
- When assembling, ensure sufficient free space to prevent crushing or take other measures to safeguard the hazard point.
- Before removing the EdEx thruster, the connected unit such as the brake must be secured to prevent movements.

7.2 Tests before commissioning

Before applying voltage to the EdEx thruster, it is necessary to perform the following parameter checks/tests.

- Operating conditions
- Order parameters
- Technical parameters

7.2.1 Operating conditions

- The EdEx thruster is assembled and connected according to regulations (⇒Assembly and installation chapter).
- The permissible voltage and frequency tolerances are adhered to (⇒Technical data chapter, Voltage and frequency section).
- The EdEx thruster is filled with the operating fluid prescribed for the usage conditions (⇒ Technical data chapter, Ambient temperature section) and for the version, and has the required fill level (⇒Maintenance chapter, Operating fluid section).
- The EdEx thruster is protected against contamination.
- The fastening bolts on the foot attachment are secured to prevent them moving inadvertently (e.g. using locking pins).
- The axes are parallel.

7.2.2 Order parameters

- Check whether the EdEx thrusters used comply with all safety-relevant parameters (e.g. thruster category, surface temperature)
- Check whether the documentation is complete and comprehensive (e.g. approvals, conditions, certificates, tests to be carried out)

7.2.3 Technical parameters

- Check the screw connections of the connection, protective conductor and equipotential bonding terminals for tightness
- Check the screw connections of the housing cover for tightness
- Check the torque of the cable entry
- Check the tightness between cable and cable gland seal
- Check whether the EdEx thruster is ready for operation

7.3 Operating modes

- Continuous operation S1 and switching operation S3 with maximum 240 c/h, up to 60 % duty cycle

8 Help with malfunctions

If used as intended, no typical malfunctions can occur on the EdEx thruster.

However, malfunctions can occur due to wear or misuse. Malfunctions on the EdEx thruster may only be rectified when the system is stopped, disconnected from the power supply and the movements have come to a standstill.

Observe the Assembly and Disassembly chapters for information on troubleshooting.

8.1 Faults and troubleshooting

Table 23: Faults and troubleshooting

Fault	Possible cause	Measure
EdEx thruster does not lift	Motor not running: Supply line interruption	Search for the interruption and rectify
	Motor not running: Switched off by trigger, e.g. motor protection switch	Check the motor protection switch and fuse elements
	Motor not running: Cable connections have poor contact	Clean corroded contacts
	Motor not running: Rotor is blocked in the stator within the bearing or close to the running wheel (pump)	Replace the thruster and send to the manufacturer for repair
	Thruster loaded too heavily: Too great an external load in addition to the brake and reset spring	Adjust load to the EdEx thruster
	Lack of operating fluid	Top up the operating fluid
	Lifting rod jammed from the outside	Rectify the jam/twisting or lateral forces in the thrusters to be driven
The EdEx thruster lifts slowly, hesitantly, jerkily	EdEx thruster loaded too heavily: Too great an external load in addition to the brake and reset spring	Adjust load to the EdEx thruster
	Lifting rod jammed from the outside	Rectify the jam/twisting or lateral forces in the thrusters to be driven
	Supply line interruption (two-phase operation)	Search for the interruption and rectify
The EdEx thruster lifts slowly, hesitantly, jerkily	Air in the pump circuit	Actuate EdEx thrusters a few times when stopped and top up the operating fluid if required
		Check the thruster's installation position and version

8 Help with malfunctions

8.1 Faults and troubleshooting



Table 23: Faults and troubleshooting

Fault	Possible cause	Measure
	Lack of operating fluid	Top up the operating fluid
Operating fluid escapes	On the lifting rod seal	Replace the EdEx thruster and send to the manufacturer for repair
	On the filling screw	Check the sealing ring, tighten the filling screw to a maximum of 65 Nm
	At the separation level between cylinder jacket and end shield	Tighten the screw connection to a maximum of 53 Nm
	On the end shield or operating fluid in the junction box	Replace the EdEx thruster and send to the manufacturer for repair
Rattling, metallic noise	Ball bearing damaged	Replace the EdEx thruster and send to the manufacturer for repair
Motor protection switch or fuse elements tripped	Short-circuited coil, phase leakage or short circuit	Check the motor's resistors and insulation, replace the EdEx thruster and send to the manufacturer for repair if required
Increased current consumption, cause	Between two phases: Short-circuited coil	Measure the resistance, replace the EdEx thruster and send to the manufacturer for repair if required
	Between all phases: Rotor is grinding or stuck	Replace the EdEx thruster and send to the manufacturer for repair

9 Maintenance

9.1 Safety instructions

- Maintenance work on the EdEx thruster may only be rectified when the system is stopped, disconnected from the power supply and secured against being switched on again.
- Maintenance work on the EdEx thruster may only be carried out when the movements have come to a standstill.
- Maintenance work on the EdEx thruster may only be carried out when the EdEx unit has cooled down.
- Maintenance work must be carried out by qualified maintenance personnel only.
- Repairs may only be carried out by the manufacturer EMG Automation GmbH, by authorised personnel or by a recognised body.
- The EdEx thruster and the connections may only be opened if no explosive atmosphere is present.
- Maintenance work on the EdEx thruster may only be carried out if no explosive atmosphere is present.
- Maintenance work on the EdEx thruster may only be carried out if the operating company has issued approval for the work.
- Only use original spare parts from the manufacturer
- The original spare parts must have the necessary thruster category.
- The fixing screws of the end shield must have a yield strength of 640 N/mm² (quality 8.8).
- The dimensions of the flame-proof gaps differ from those in EN 60079-1. For information on dimensions, please contact the manufacturer EMG Automation GmbH.
- Repairs may only be carried out by authorised personnel.
- Clean only using a damp cloth (ESD danger)
- If maintenance and repair work is inadequate, there is a risk of leaks, which could lead to an explosion.

9.2 Maintenance tasks



WARNING

Hot surface

Stored residual heat poses a risk of burns if you touch the housing surface

- EdEx thrusters can reach housing surface temperatures of up to 100 °C in continuous mode S1 or in very high switching mode S3.
- The EdEx thruster must cool off before starting maintenance work.



WARNING

Spraying hydraulic oil

Risk of injury (e.g. face and eyes) due to spraying hydraulic oil

- The EdEx thruster must be secured to prevent a restart before opening.
- Only turn the filling screw slowly.
- Only specialists are permitted to unscrew and remove the filling screw.



WARNING

Pre-tensioned reset spring

Risk of injury when opening the EdEx thruster due to the pre-tensioned reset spring.

- Never attempt to open the EdEx thruster in order to access the reset spring.
- The EdEx thruster may only be opened by instructed specialists with corresponding training and special tools (e.g. disassembly tools for thrusters with C-springs)

⚠ WARNING

Cylinder movements

Risk of crushing between surrounding hindrances and the cylinder or connected components as a result of the cylinder retracting automatically due to the reset spring with a hydraulic pressure drop, or if the power supply is interrupted.

- Switching the motor off returns the cylinder to the limit position.
- Before removing the EdEx thruster, the connected unit such as the brake must be secured to prevent movements.

9.2.1 Operating fluid

EdEx thrusters are delivered from the factory with operating fluid that depends on the usage conditions and the required version. The type of operating fluid that the thruster was filled with is specified on the type plate. EdEx thrusters must be operated exclusively with the hydraulic medium specified on the type plate.

NOTICE

Observe the safety data sheet issued by the oil manufacturer. The type of operating fluid already in the thruster must always be used to top it up.

Table 24: Fill quantities for operating fluid

Short lift type	Fill quantity in litres	Long lift type	Fill quantity in litres
EdEx 32/50	2.4	EdEx 80/160	6.0
EdEx 50/50	2.4	EdEx 125/160	6.0
EdEx 80/60	3.9	EdEx 150/160	6.0
EdEx 80/75	3.9	EdEx 200/160	11.1
EdEx 125/60	3.9	EdEx 250/160	11.1
EdEx 125/75	3.9	EdEx 320/160	11.1
EdEx 150/60	3.9		
EdEx 150/75	3.9		
EdEx 200/60	7.4		
EdEx 250/60	7.4		
EdEx 320/100	10.8		

EdEx thrusters are filled with Pentosin operating fluid (hydraulic oil) of class HL10 DIN 51524 for the temperature range of -25 °C to +40 °C when delivered. Special operating fluids are required for other temperature ranges (⇒ Technical data chapter, Operating fluid section).

9.2.2 Intervals for renewing the operating fluid

Predominantly continuous operation S1

- after 18 months in operation

Predominantly switching operation S3

- after 1.5 million duty cycles

9.2.3 Checking the operating fluid



WARNING

Hot operating fluid

Risk of burns due to hot oil plumes upon opening the filling screw when at operational temperature.

- The operating fluid may only be checked, topped up or drained when switched off and cool.
- The EdEx thruster may only be opened at a maximum temperature of 40 °C.

NOTICE

If not filled sufficiently, the thruster does not develop the full lifting force.

If overfilled, the thruster's internal pressure is impermissibly high.

The EdEx thrusters are filled correctly if the operating fluid level reaches the lower edge within the filling opening when the thruster is upright and the lifting rod is retracted.



Observe the disassembly instructions if the EdEx thruster is not installed upright (⇒ Disassembly chapter).

- Set the EdEx thruster upright.
- Remove the screw plug from the filling nozzle.

- Check the fill level according to the EdEx type and top up if required.

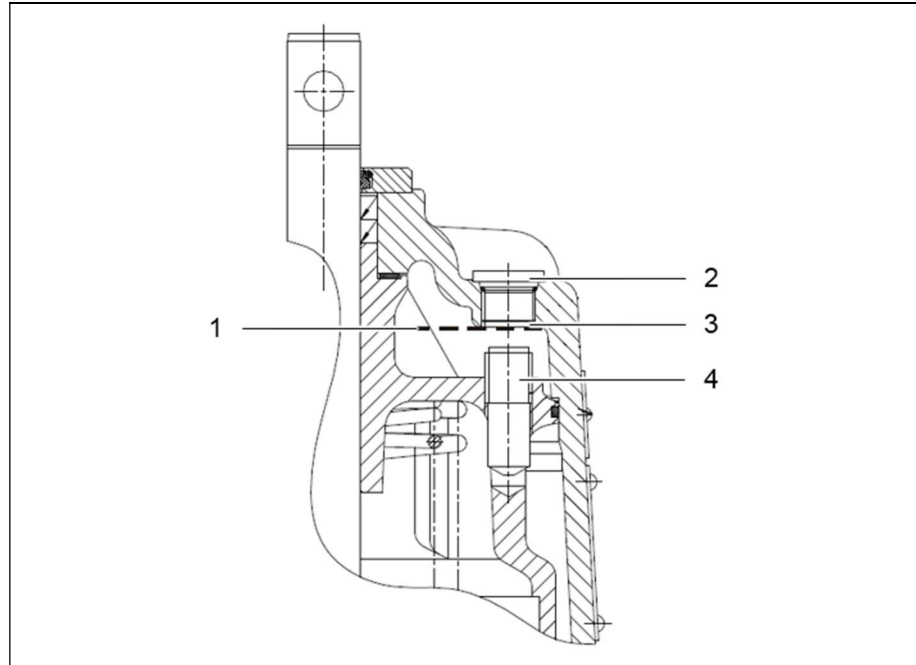

Figure 12: Adjustment parts, lifting/lowering/throttle valve

- 1 Fill level
- 2 Screw plug
- 3 Filling opening
- 4 Regulating screw

Topping up the operating fluid

- Fill the EdEx thruster with operating fluid up to the filling nozzle bottom edge. Perform several lifting movements while doing so in order to prevent air entering the system.
- Check the fill level again and top up if required.
- Close the filling screw and, if present, the overflow screw tight (tightening torque: 65 Nm).
- Return the EdEx thruster to its original installation position (⇒ Assembly chapter).

9.2.4 Seals

The EdEx thruster must be checked for leaks at least 1 x per year.

9.2.5 Changing the operating fluid

 **WARNING**

Hot operating fluid

Risk of burns due to hot oil plumes upon opening the filling screw when at operational temperature.

- The operating fluid may only be checked, topped up or drained when switched off and cool.
- The EdEx thruster may only be opened at a maximum temperature of 40 °C.

NOTICE

If not filled sufficiently, the thruster does not develop the full lifting force.

If overfilled, the thruster's internal pressure is impermissibly high.

- Position the EdEx thruster vertically above a suitable collecting container
- Remove filler and drain plug.
- After the thruster has been completely emptied, close the drainage opening firmly again
- New operating fluid (⇒ data on type plate)



The explosion-proof EdEx thruster is filled correctly if the fluid level reaches the lower edge within the filling opening when the thruster is upright and the lifting rod is retracted.

- Perform several lifting movements to avoid possible air pockets
- Then check the fill level again and top up operating fluid if necessary
- Tightly close the filler plug when the required fill level is reached
- Dispose of used liquid (⇒ Disposal chapter).

9.3 Maintenance schedule

Table 25: Maintenance log for EdEx thrusters

EdEx type			
Serial number			
System ID			
Classification according to section 3.1 (table 1)	Low requirements	Standard	Higher requirements
	θ	θ	θ

Test object	Test interval according to classification			Test performed	Test passed	Evaluation / measured values
	as required	as required	as required			
Cleaning	as required	as required	as required	θ	θ	
Test run	Every six months			θ	θ	
Visual checks						
Leaks	Annually	Annually	Every six months	θ	θ	
Bolt connections	Annually	Annually	Every six months	θ	θ	
Terminal box cover	Annually	Annually	Every six months	θ	θ	
Cable connections tight	Annually	Annually	Every six months	θ	θ	
External damage	Annually	Annually	Every six months	θ	θ	
Functional inspection						
Motor functions, running noises		Annually	Annually	θ	θ	
max. lifting path		Annually	Annually	θ	θ	
Terminal box and cable infeed leak tightness		Annually	Annually	θ	θ	
Position indicator, signals, adjustment		Annually	Annually	θ	θ	
Extended test						
Actuating force measurement			Every 2-3 years	θ	θ	
Reset force measurement			Every 2-3 years	θ	θ	
Power consumption measurement			Every 2-3 years	θ	θ	
Insulation resistance measurement			Every 2-3 years	θ	θ	
Coil resistance measurement			Every 2-3 years	θ	θ	

9 Maintenance

9.3 Maintenance schedule



Test object	Test interval according to classification		Test performed	Test passed	Evaluation / measured values
Proof of insulation reliability in accordance with DIN 57530 part 1 / VDE 0530 section 17.1		Every 2-3 years	θ	θ	
Maintenance Replacing all wear parts (bearings, seals, operating fluids, etc.)		Recommendation: Every 5 years or after 5 million switching cycles			

Summary	Complete test passed	Repair required	Next test
	θ	θ	

Confirmation	The test was performed in accordance with the manufacturer's maintenance manual.			
	Location/date	Company	Tester	Signature

9.3.1 Classification

Table 26: Classification

Classification	Low requirements	Standard	Higher requirements
by safety profile	Applications in functions and areas with low safety requirements	Applications in functions and areas with normal safety requirements	Applications in functions and areas with very high safety requirements
or by operating profile	Mainly at a standstill, operation irregular and seldom	Operated in average value ranges of the permissible operating data according to type plate	Operated in limit value ranges of the permissible operating data according to type plate
Test run	Every six months		
Visual checks	Annually	Annually	Every six months
Functional inspection		Annually	Annually
Extended test			Every 2-3 years
Maintenance		Recommendation: Every 5 years or after 5 million switching cycles	

10 Disassembly

10.1 Safety instructions

The following safety regulations must be adhered to before beginning any work on EdEx thrusters:

- Ensure that the industrial system is shut down.
- Disassembly may only be carried out if no explosive atmosphere is present.
- De-energise the system.
- Safeguard the system to prevent it being switched on again.
- Test to ensure a de-energised state.
- Cover or isolate adjacent live parts.



WARNING

Opening the EdEx thrusters

Risk of injury due to tensioned C-springs.

- Only service partners authorised by the manufacturer are permitted to dismantle the EdEx thrusters outside the manufacturer's factory.



CAUTION

Switch-off due to any C-springs, brake springs, brake weights that may be installed or due to other external influences

Risk of crushing due to the lifting rod

- The downstream drive must be secured before removing the EdEx thrusters, because the lifting rod retracts automatically.

10.2 Disconnecting the electrical connections



DANGER

Live components

Fatal electric shock or serious burns.

- Work on live components may only be performed by electricians.
- First disconnect the electrical power supply.
- The earthing conductor must be disconnected after all other cables.



Observe the allocations in the terminal diagram (⇒Assembly chapter, Electrical connection section).

- First disconnect the electrical power supply.
- Disconnect the earthing conductor after all other cables.

10.3 Removal



CAUTION

Switch-off due to any C-springs, brake springs, brake weights that may be installed or due to other external influences

Risk of crushing due to the lifting rod

- The downstream drive must be secured before removing the EdEx thrusters, because the lifting rod retracts automatically.



CAUTION

The EdEx thrusters weigh between 30 and 90 kg

Risk of injury when lifting the load manually.

- Use suitable lifting equipment (e.g. crane).
- Never remain below suspended loads.
- Use a transport aid (e.g. lifting carriage) with sufficient load bearing capacity.

NOTICE

Suitable measures must be taken to prevent the EdEx thrusters falling before removing them. The EdEx thrusters weigh between 30 and 90 kg.

NOTICE

The lifting rod must not be damaged or contaminated, e.g. by paint as a result of painting the entire system. A failure to observe this will destroy the lifting rod.

Process

1. Secure the EdEx thruster to prevent it falling.
2. Pull the bolt out of the lifting rod.
3. Attach the lifting gear to the EdEx thruster.
4. Remove the bolt from the foot hole.
5. Use the lifting gear to remove the EdEx thruster.

11 Disposal

11.1 Disposal consideration



11 Disposal

11.1 Disposal consideration



WARNING

Opening the EdEx thrusters

Risk of injury due to tensioned C-springs.

- Only service partners authorised by the manufacturer are permitted to dismantle the EdEx thrusters outside the manufacturer's factory.

The manufacturer can dispose of EdEx thrusters for a charge in accordance with the applicable terms and conditions after they have been dismantled properly.

When disposing of the EdEx thrusters and their process media, observe the following points:

- Observe national regulations on site.
- Observe company-specific requirements.
- Dispose of the operating fluid (oil filling), the plastic parts and the metal parts separately.
- Used process media must be disposed of in accordance with the respective valid safety data sheets.

12 Lists

12.1 Index of figures

Figure 1:	Thruster identification.....	22
Figure 2:	Explosion protection identification	23
Figure 3:	Type plate	24
Figure 4:	Test plate	25
Figure 5:	Type EdEx.....	31
Figure 6:	Type EdEx-HV	32
Figure 7:	Design of EdEx thruster	36
Figure 8:	Attachment point	41
Figure 9:	Terminal diagram EdEx thruster – 3-pin	49
Figure 10:	Terminal diagram EdEx-HV thrusters – 6-pin	50
Figure 11:	Regulating screw lifting/lowering/throttle valve	54
Figure 12:	Adjustment parts, lifting/lowering/throttle valve.....	65
Figure 13:	EU Declaration of Conformity	74

12.2 Index of tables

Table 1:	Format conventions	8
Table 2:	Terms and abbreviations	10
Table 3:	Use in zones in potentially explosive areas	15
Table 4:	Responsible staff	19
Table 5:	EdEx identification	23
Table 6:	Characteristics – short lift thrusters EdEx 32/50-EdEx 150/75.....	26
Table 7:	Characteristics – short lift thrusters EdEx 200/60-EdEx 320/100.....	26
Table 8:	C-spring characteristics – short lift thrusters EdEx 32/50-EdEx 125/75.....	27
Table 9:	C-spring characteristics – short lift thrusters EdEx 125/60-EdEx 200/60.....	27
Table 10:	C-spring characteristics – short lift thrusters EdEx 200/60-EdEx 320/100.....	27
Table 11:	Characteristics – long lift thrusters EdEx 80/160-EdEx 320/120.....	28
Table 12:	C-spring characteristics – long lift thrusters EdEx 80/160-EdEx 150/160.....	29
Table 13:	C-spring characteristics – long lift thrusters EdEx 200/160-EdEx 250/160.....	29
Table 14:	C-spring characteristics – long lift thrusters EdEx 320/120.....	29
Table 15:	Time data of the lowering and resetting movement.....	30
Table 16:	Dimensions type EdEx.....	31
Table 17:	Dimensions type EdEx-HV.....	32
Table 18:	Electrical voltage and frequency (basic version)	33
Table 19:	Operating behaviour depending on the ambient temperature	33
Table 20:	Ambient temperatures for EdEx thrusters.....	34
Table 21:	Classification of EdEx thrusters/type groups	35
Table 22:	Cable entry – cable diameter	53
Table 23:	Faults and troubleshooting.....	59
Table 24:	Fill quantities for operating fluid	63
Table 25:	Maintenance log for EdEx thrusters.....	67
Table 26:	Classification	68
Table 27:	Further applicable documents.....	75

13 Appendix

13.1 EU Declaration of Conformity



13 Appendix

13.1 EU Declaration of Conformity



	EU declaration of conformity	
Manufacturer:	EMG Automation GmbH Industriestraße 1 D-57482 Wenden Germany	
Product (device):	Electrohydraulic thruster ELDRO® EdEx **/** and EdEx **/** HV	
Device type	EdEx32/50; EdEx50/50; EdEx80/60; EdEx80/75; EdEx125/60; EdEx125/75; EdEx150/60; EdEx150/75; EdEx200/60; EdEx250/60; EdEx320/100; EdEx80/160; EdEx125/160; EdEx150/160; EdEx200/160; EdEx250/160; EdEx320/120	
The manufacturer bears sole responsibility for issuing this declaration of conformity.		
The subject of the declaration described above complies with the relevant Union harmonization legislation:		
<ul style="list-style-type: none"> ▪ ATEX directive 2014/34/EU ▪ Machinery directive 2006/42/EG ▪ Low voltage directive 2014/35/EU ▪ EMV directive 2014/30/EU ▪ RoHS-directive 2011/65/EU 		
Indication of the relevant harmonized standards or other technical specifications for the ATEX directive that were used as the basis for the declaration of conformity:		
EN 1127-1:2011	Explosive atmospheres - Explosion prevention and protection - Part 1: Basic concepts and methodology	
EN IEC 60079-0: 2018	Explosive atmospheres - Part 0: Equipment - General requirements	
EN 60079-1:2014	Explosive atmospheres - Part 1: Equipment protection by flameproof enclosures "d"	
EN IEC 60079-7:2015+A1:2018	Explosive atmospheres - Part 7: Equipment protection by increased safety "e"	
EN 60079-31:2014	Explosive atmospheres - Part 31: Equipment dust ignition protection by enclosure "t"	
EN 13463-1:2009	Non-electrical equipment for explosive atmospheres – Part 1: Basic method and requirements	
EN 13463-8:2003	Non-electrical equipment for potentially explosive atmospheres - Part 8: Protection by liquid immersion 'k'	
The notified body DEKRA EXAM GmbH (identification number: 0158) has carried out the EU type examination and issued the following certificate: BVS 05 ATEX E 074 X		
The product is manufactured under the quality assurance system production (Annex IV of the ATEX directive). This has been recognized by the notified body DEKRA EXAM GmbH (identification number: 0158).		
Signatory of the declaration:	 Harald Rackel – Managing directors	
Germany-57482 Wenden, dated		

Figure 13: EU Declaration of Conformity

