



The Driver's Seat KFS9 is ergonomically designed and provides a high grade of comfort. The Driver's Seat is a low level mechanical suspension seat with an oil-hydraulic vibration absorption system with weight adjustment. Upon request, a pneumatic vibrating system with weight adjustment is available. All adjustment controls are positioned ergonomically within easy access. The metal parts are protected against corrosion and painted black.

Technical data

Suspension stroke	80 mm
Weight adjustment	50 - 150 kg (pneumatic)
	50 - 130 kg (mechanical)
Horizontal adjustment	160 mm
Inclination of the backrest	max. 90°
Height and slope adjustment	60 mm



		Example				
		KFS 92	-A1	-L2	-S1	-P
Driver's Seat						
KFS91	Driver's Seat with air-permeable artificial leather cover black					
KFS92	Driver's Seat with textile cover black					
Attachments						
K	Headrest rain					
A1	Armrest adjustable (2 pieces) 50 mm wide					
A2	Armrest continuously adjustable (2 pieces) 100 mm wide					
L1	Lumbar support manual adjustment - 2 movement					
L2	Lumbar support manual adjustment - 4 movement					
B	Seat allocation recognition					
H	Seat cushion and backrest standard with heating element 24 V DC 47W					
S1	Safety belt 2 point fixing (automatic)					
S2	Safety belt 4 point fixing (headrest required)					
S3	Safety belt 2 point fixing (static)					
V	Seat cushion with V-cut (LD required!)					
LD	Horizontal adjustment dual (seat height +30 mm!)					
P	Pneumatic vibration absorption system with weight adjustment (incl. compressor)					
LK	Plate for horizontal manual adjustment of seat adjustable +/-250 mm					
C1	Loose cover for Driver's Seat KFS 9					
C2	Loose cover for Driver's Seat KFS 9 with V-cut					
U	Console (base)					

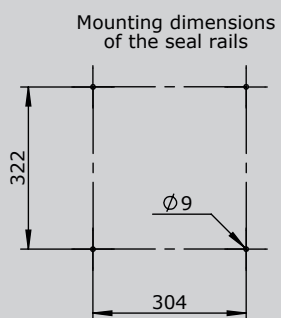
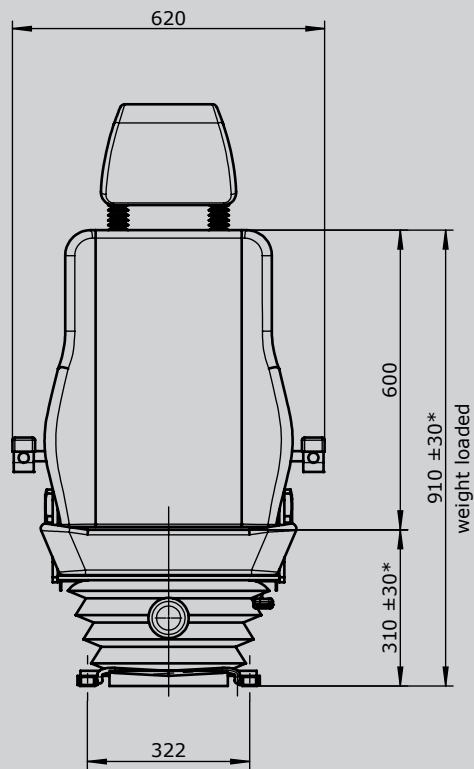
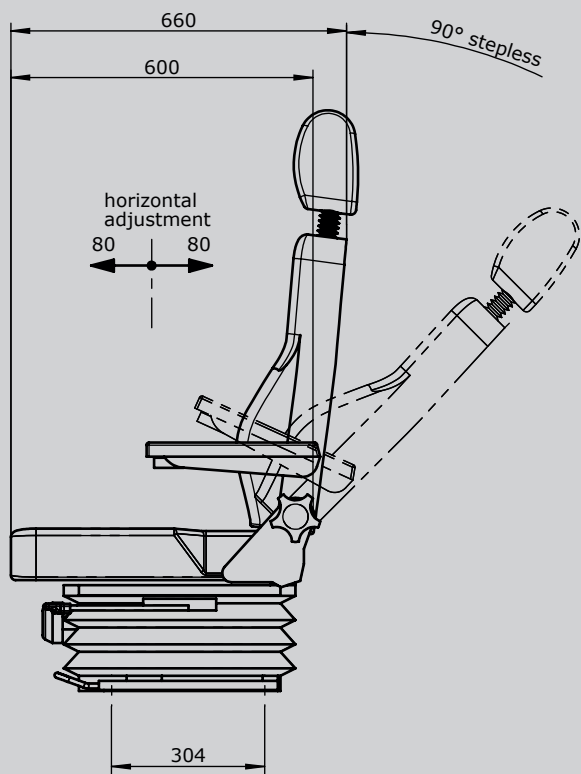

Seat cushion
v-cutout

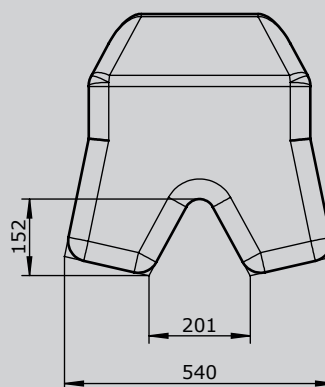

* adjustable