

Multi-Axis Controller V20



The V20 is a rugged switching device for remote control. The integrated sensor technology has signal and potentiometer tracks in conductive plastic technology. Detent points can be integrated as an option.

Technical data

Mechanical life V20	3 million operating cycles
Operation temperature	-40°C to +85°C
Degree of protection	IP65 (optional IP67)

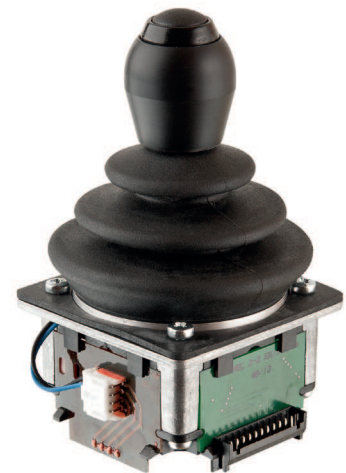

		V20	-P	Example D	-C71	+C71	-B	-X
Basic unit								
V20.1	1-axis with spring return							
V20	2-axis with spring return							
V20.1A	1-axis with spring return, IP67 front							
V20A	2-axis with spring return, IP67 front							
Gate								
p	Cross gate							
P X	Special gate							
Grip								
	Knob (standard)							
D	Push button							
GS9	Hall-twist grip with spring return							
GS9-D	Hall-twist grip with spring return and push button on top							
Axis 1: direction 1-2								
C70	Mechanical encoder							
	MEC 2-1							
	EA/15-10				I max. 1 mA			
	Potentiometer track				2 x 5 kOhm			
	Direction track				Arrangement MS224-0			
C71	Mechanical encoder							
	MEC 2-2							
	EA/11-10				I max. 1 mA			
	Potentiometer track				2 x 5 kOhm			
	Direction track				Arrangement MS24-0			
C72	Mechanical encoder							
	MEC 2-5							
	EA/21-10				I max. 1 mA			
	Potentiometer track				2 x 5 kOhm			
	Direction track				Arrangement MS25-0			
Axis 2: direction 3-4								
See description axis 1!								
Cover housing								
B	Cover housing KBQ 905 (IP65)							
Special model								
X	Special / customer specified							

Technical details may vary based on configuration or application! Technical data subject to change without notice!

V20 Standard degree of protection front IP 65

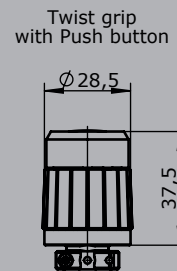
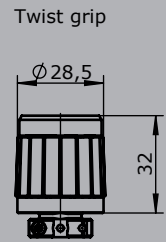
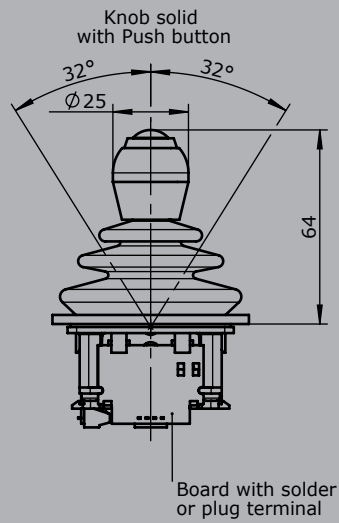
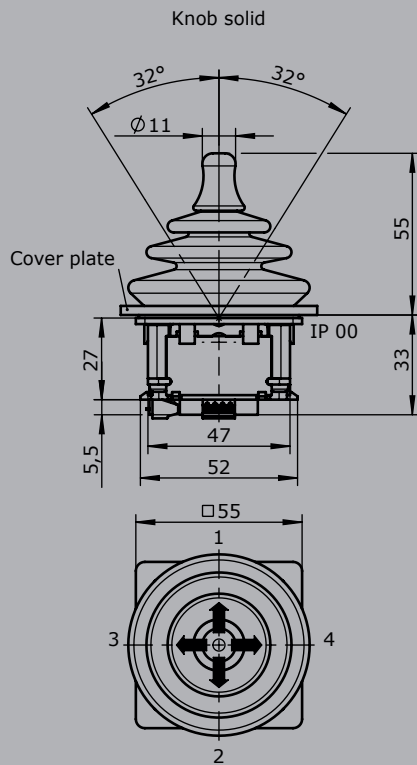

V20 Degree of protection front IP 67

